

**ANNEX I**  
**SUMMARY OF PRODUCT CHARACTERISTICS**

▼ This medicinal product is subject to additional monitoring. This will allow quick identification of new safety information. Healthcare professionals are asked to report any suspected adverse reactions. See section 4.8 for how to report adverse reactions.

## **1. NAME OF THE MEDICINAL PRODUCT**

Hemlibra 30 mg/mL solution for injection  
Hemlibra 150 mg/mL solution for injection

## **2. QUALITATIVE AND QUANTITATIVE COMPOSITION**

### Hemlibra 30 mg/mL solution for injection

Each mL of solution contains 30 mg of emicizumab\*

Each vial of 1 mL contains 30 mg of emicizumab at a concentration of 30 mg/mL.

### Hemlibra 150 mg/mL solution for injection

Each mL of solution contains 150 mg of emicizumab\*

Each vial of 0.4 mL contains 60 mg of emicizumab at a concentration of 150 mg/mL.

Each vial of 0.7 mL contains 105 mg of emicizumab at a concentration of 150 mg/mL.

Each vial of 1 mL contains 150 mg of emicizumab at a concentration of 150 mg/mL.

\* produced by recombinant DNA technology using mammalian Chinese Hamster Ovary (CHO) cell culture

For the full list of excipients, see section 6.1

## **3. PHARMACEUTICAL FORM**

Solution for injection.

Colourless to slightly yellow solution.

## **4. CLINICAL PARTICULARS**

### **4.1 Therapeutic indications**

Hemlibra is indicated for routine prophylaxis of bleeding episodes in patients with haemophilia A with factor VIII inhibitors.

Hemlibra can be used in all age groups.

### **4.2 Posology and method of administration**

Treatment should be initiated under the supervision of a physician experienced in the treatment of haemophilia and/or bleeding disorders.

## Posology

Treatment (including routine prophylaxis) with bypassing agents (e.g. aPCC and rFVIIa) should be discontinued the day before starting Hemlibra therapy (see section 4.4).

The recommended dose is 3 mg/kg once weekly for the first 4 weeks (loading dose), followed by 1.5 mg/kg once weekly (maintenance dose), administered as a subcutaneous injection.

The patient dose (in mg) and volume (in mL) should be calculated as follows:

- Loading dose (3 mg/kg) once weekly for the first 4 weeks:  
Patient bodyweight (kg) x dose (3 mg/kg) = total amount (mg) of emicizumab to be administered
- Followed by a maintenance dose (1.5 mg/kg) once weekly from week 5 on:  
Patient bodyweight (kg) x dose (1.5 mg/kg) = total amount (mg) of emicizumab to be administered

The total volume of Hemlibra to be injected subcutaneously is calculated as follows:

Total amount (mg) of emicizumab to be administered ÷ vial concentration (mg/mL) = total volume of Hemlibra (mL) to be injected.

Different Hemlibra concentrations (30 mg/mL and 150 mg/mL) should not be combined when making up the total volume to be administered.

A volume greater than 2 mL per injection should not be administered.

### Examples:

Patient's bodyweight of 60 kg:

- Loading dose (first 4 weeks) example:  $60 \text{ kg} \times 3 \text{ mg/kg} = 180 \text{ mg}$  of emicizumab needed for the loading dose.
- To calculate the volume to be administered divide calculated dose 180 mg by 150 mg/mL:  $180 \text{ mg of emicizumab} \div 150 \text{ mg/mL} = 1.20 \text{ mL}$  of 150 mg/mL Hemlibra concentration to be injected.
- Choose appropriate dosage and volume from vial strengths available.
- Maintenance dose (from week 5 on) example:  $60 \text{ kg} \times 1.5 \text{ mg/kg} = 90 \text{ mg}$  of emicizumab needed for the maintenance dose.
- To calculate the volume to be administered divide calculated dose 90 mg by 150 mg/mL:  $90 \text{ mg of emicizumab} \div 150 \text{ mg/mL} = 0.6 \text{ mL}$  of 150 mg/mL Hemlibra concentration to be injected.
- Choose appropriate dosage and volume from vial strengths available.

Patient's bodyweight of 16 kg:

- Loading dose (first 4 weeks) example:  $16 \text{ kg} \times 3 \text{ mg/kg} = 48 \text{ mg}$  of emicizumab needed for the loading dose.
- To calculate the volume to be administered divide calculated dose 48 mg by 150 mg/mL:  $48 \text{ mg of emicizumab} \div 150 \text{ mg/mL} = 0.32 \text{ mL}$  of 150 mg/mL Hemlibra concentration to be injected.
- Choose appropriate dosage and volume from vial strengths available.
- Maintenance dose (from week 5 on) example:  $16 \text{ kg} \times 1.5 \text{ mg/kg} = 24 \text{ mg}$  of emicizumab needed for the maintenance dose.
- To calculate the volume to be administered divide calculated dose 24 mg by 30 mg/mL:  $24 \text{ mg of emicizumab} \div 30 \text{ mg/mL} = 0.8 \text{ mL}$  of 30 mg/mL Hemlibra concentration to be injected.
- Choose appropriate dosage and volume from vial strength available.

### *Duration of treatment*

Hemlibra is intended for long-term prophylactic treatment.

### *Dosage adjustments during treatment*

No dosage adjustments of Hemlibra are recommended.

### *Delayed or missed doses*

If a patient misses a scheduled weekly subcutaneous injection of Hemlibra, the patient should be instructed to take the missed dose as soon as possible, up to a day before the day of the next scheduled dose. The patient should then administer the next dose on the usual scheduled dosing day. The patient should not take a double dose to make up for a missed dose.

### Special populations

#### *Paediatric*

No dose adjustments are recommended in paediatric patients (see section 5.2). There are no data in patients less than 1 year of age.

#### *Elderly*

No dose adjustments are recommended in patients  $\geq 65$  years of age (see section 5.2). There are no data in patients over 75 years old.

#### *Renal and hepatic impairment*

No dose adjustments are recommended in patients with mild renal or mild and moderate hepatic impairment (see section 5.2). Emicizumab has not been studied in patients with moderate or severe renal impairment or severe hepatic impairment

#### *Management in the perioperative setting*

The safety and efficacy of emicizumab have not been formally evaluated in the surgical setting. If bypassing agents (e.g. aPCC and rFVIIa) are required in the perioperative period, please refer to the dosing guidance on the use of bypassing agents in section 4.4.

#### *Immune tolerance induction (ITI)*

The safety and efficacy of emicizumab in patients receiving ongoing immune tolerance induction have not yet been established. No data are available.

### Method of administration

Hemlibra is for subcutaneous use only, and it should be administered using appropriate aseptic technique (see section 6.6).

The injection should be restricted to the recommended injection sites: the abdomen, the upper outer arms and the thighs (see section 5.2).

Administration of Hemlibra subcutaneous injection in the upper outer arm should be performed by a caregiver or healthcare professional.

Alternating the site of injection may help prevent or reduce injection site reactions (see section 4.8). Hemlibra subcutaneous injection should not be administered into areas where the skin is red, bruised, tender or hard, or areas where there are moles or scars.

During treatment with Hemlibra, other medicinal products for subcutaneous administration should, preferably, be injected at different anatomical sites.

### *Administration by the patient and/or caregiver*

Hemlibra is intended for use under the guidance of a healthcare professional. After proper training in subcutaneous injection technique, a patient may self-inject Hemlibra, or the patient's caregiver may administer it, if their physician determines that it is appropriate.

The physician and the caregiver should determine the appropriateness of the child self-injecting Hemlibra. However, self-administration is not recommended for children below 7 years of age.

For comprehensive instructions on the administration of Hemlibra, see section 6.6 and package leaflet.

### **4.3 Contraindications**

Hypersensitivity to the active substance or to any of the excipients listed in section 6.1.

### **4.4 Special warnings and precautions for use**

#### Traceability

In order to improve traceability of biological medicinal products, the name and the batch number of the administered product should be clearly recorded.

#### Thrombotic microangiopathy associated with Hemlibra and activated prothrombin complex concentrate

Cases of thrombotic microangiopathy (TMA) were reported from a clinical trial in patients receiving Hemlibra prophylaxis when on average a cumulative amount of >100U/kg/24 hours of activated prothrombin complex concentrate (aPCC) for 24 hours or more was administered (see section 4.8). Treatment for the TMA events included supportive care with or without plasmapheresis and haemodialysis. Evidence of improvement was seen within one week following discontinuation of aPCC and interruption of Hemlibra. This rapid improvement is distinct from the usual clinical course observed in atypical hemolytic uremic syndrome and classic TMAs, such as thrombotic thrombocytopenic purpura (see section 4.8). One patient resumed Hemlibra following resolution of TMA and continued to be treated safely.

Patients receiving Hemlibra prophylaxis should be monitored for the development of TMA when administering aPCC. The physician should immediately discontinue aPCC and interrupt Hemlibra therapy if clinical symptoms and/or laboratory findings consistent with TMA occur, and manage as clinically indicated. Physicians and patients/caregivers should weigh the benefits and risks of resuming Hemlibra prophylaxis following complete resolution of TMA on a case-by-case basis. In case a bypassing agent is indicated in a patient receiving Hemlibra prophylaxis, see below for dosing guidance on the use of bypassing agents.

Caution should be used when treating patients who are at high risk for TMA (e.g. have a previous medical history or family history of TMA), or those who are receiving concomitant medications known to be a risk factor for the development of TMA (e.g. ciclosporin, quinine, tacrolimus).

#### Thromboembolism associated with Hemlibra and activated prothrombin complex concentrate

Serious thrombotic events were reported from a clinical trial in patients receiving Hemlibra prophylaxis when on average a cumulative amount of >100U/kg/24 hours of aPCC for 24 hours or more was administered (see section 4.8). No cases required anticoagulation therapy. Following discontinuation of aPCC and interruption of Hemlibra, evidence of improvement or resolution was

seen within one month (see section 4.8). One patient resumed Hemlibra following resolution of thrombotic event and continued to be treated safely.

Patients receiving Hemlibra prophylaxis should be monitored for the development of thromboembolism when administering aPCC. The physician should immediately discontinue aPCC and interrupt Hemlibra therapy if clinical symptoms, imaging, and/or laboratory findings consistent with thrombotic events occur, and manage as clinically indicated. Physicians and patients/caregivers should weigh the benefits and risks of resuming Hemlibra prophylaxis following complete resolution of thrombotic events on a case-by-case basis. In case a bypassing agent is indicated in a patient receiving Hemlibra prophylaxis, see below for dosing guidance on the use of bypassing agents.

#### Guidance on the use of bypassing agents in patients receiving Hemlibra prophylaxis

Treatment with bypassing agents should be discontinued the day before starting Hemlibra therapy.

Physicians should discuss with all patients and/or caregivers the exact dose and schedule of bypassing agents to use, if required while receiving Hemlibra prophylaxis.

Hemlibra increases the patient's coagulation potential. The bypassing agent dose required may therefore be lower than that used without Hemlibra prophylaxis. The dose and duration of treatment with bypassing agents will depend on the location and extent of bleeding, and the patient's clinical condition. Use of aPCC should be avoided unless no other treatment options/alternatives are available. If aPCC is indicated in a patient receiving Hemlibra prophylaxis, the initial dose should not exceed 50 U/kg and laboratory monitoring is recommended (including but not restricted to renal monitoring, platelet testing, and evaluation of thrombosis). If bleeding is not controlled with the initial dose of aPCC up to 50 U/kg, additional aPCC doses should be administered under medical guidance or supervision with consideration made to laboratory monitoring for the diagnosis of TMA or thromboembolism and verification of bleeds prior to repeated dosing. The total aPCC dose should not exceed 100 U/kg in the first 24-hours of treatment. Treating physicians must carefully weigh the risk of TMA and thromboembolism against the risk of bleeding when considering aPCC treatment beyond a maximum of 100 U/kg in the first 24-hours.

In clinical trials, no cases of TMA or thrombotic events were observed with use of activated recombinant human FVII (rFVIIa) alone in patients receiving Hemlibra prophylaxis.

Bypassing agent dosing guidance should be followed for at least 6 months following discontinuation of Hemlibra prophylaxis (see section 5.2).

#### Effects of emicizumab on coagulation tests

Emicizumab replaces the tenase cofactor activity of activated factor VIII (FVIIIa). Coagulation laboratory tests based on intrinsic clotting, including the activated clotting time (ACT), activated partial thromboplastin time (e.g. aPTT), measure the total clotting time including time needed for activation of FVIII to FVIIIa by thrombin. Such intrinsic pathway based tests will yield overly shortened clotting times with emicizumab, which does not require activation by thrombin. The overly shortened intrinsic clotting time will then disturb all single factor assays based on aPTT, such as the one stage FVIII activity assay (see section 4.4, Table 1). However, single factor assays utilising chromogenic or immuno-based methods are not affected by emicizumab and may be used to monitor coagulation parameters during treatment, with specific considerations for FVIII chromogenic activity assays as described below.

Chromogenic factor VIII activity tests may be manufactured with either human or bovine coagulation proteins. Assays containing human coagulation factors are responsive to emicizumab but may overestimate the clinical haemostatic potential of emicizumab. In contrast, assays containing bovine coagulation factors are insensitive to emicizumab (no activity measured) and can be used to monitor endogenous or infused factor VIII activity, or to measure anti FVIII inhibitors.

Emicizumab remains active in the presence of inhibitors against factor VIII and so will produce a false negative result in clotting based Bethesda assays for functional inhibition of factor VIII. Instead, a chromogenic Bethesda assay utilising a bovine based factor VIII chromogenic test that is insensitive to emicizumab may be used.

These two pharmacodynamic markers do not reflect the true haemostatic effect of emicizumab *in vivo* (aPTT is overly shortened and reported factor VIII activity may be overestimated) but provide a relative indication of the pro-coagulant effect of emicizumab.

In summary, intrinsic pathway clotting-based laboratory test results in patients treated with Hemlibra should not be used to monitor its activity, determine dosing for factor replacement or anti-coagulation, or measure factor VIII inhibitors titers. Caution should be taken if intrinsic pathway clotting based laboratory tests are used, as misinterpretation of their results may lead to under-treatment of patients experiencing bleeding episodes, which can potentially result in severe or life-threatening bleeds.

Laboratory tests unaffected by emicizumab are also shown in Table 1 below. Due to its long half-life, these effects on coagulation assays may persist for up to 6 months after the last dose (see section 5.2).

**Table 1 Coagulation test results affected and unaffected by emicizumab**

Results Affected by emicizumab	Results Unaffected by emicizumab
<ul style="list-style-type: none"> <li>- Activated partial thromboplastin time (aPTT)</li> <li>- Bethesda assays (clotting-based) for FVIII inhibitor titers</li> <li>- One-stage, aPTT-based, single-factor assays</li> <li>- aPTT-based activated protein C resistance (APC-R)</li> <li>- Activated clotting time (ACT)</li> </ul>	<ul style="list-style-type: none"> <li>- Bethesda assays (bovine chromogenic) for FVIII inhibitor titers</li> <li>- Thrombin time (TT)</li> <li>- One-stage, prothrombin time (PT)-based, single-factor assays</li> <li>- Chromogenic-based single-factor assays other than FVIII<sup>1</sup></li> <li>- Immuno-based assays (e.g. ELISA, turbidimetric methods)</li> <li>- Genetic tests of coagulation factors (e.g. Factor V Leiden, Prothrombin 20210)</li> </ul>

<sup>1</sup>For important considerations regarding FVIII chromogenic activity assays, see section 4.4.

#### Paediatric population

There are no data in children <1 year of age. The developing hemostatic system in neonates and infants is dynamic and evolving, and the relative concentrations of pro- and anticoagulant proteins in these patients should be taken into consideration when making a benefit-risk assessment, including potential risk of thrombosis (e.g. central venous catheter-related thrombosis).

#### **4.5 Interaction with other medicinal products and other forms of interaction**

No adequate or well-controlled drug-drug interaction studies have been conducted with emicizumab.

Clinical experience indicates a drug interaction exists with emicizumab and aPCC (see sections 4.4 and 4.8).

There is a possibility for hypercoagulability with rFVIIa or FVIII with emicizumab based on preclinical experiments. Emicizumab increases coagulation potential, therefore the coagulation factor dose required to achieve hemostasis may be lower than when used without Hemlibra prophylaxis.

Experience with concomitant administration of anti-fibrinolytics with aPCC or rFVIIa in patients receiving emicizumab prophylaxis is limited. However, the possibility of thrombotic events should be considered when systemic anti-fibrinolytics are used in combination with aPCC or rFVIIa in patients receiving emicizumab.

#### **4.6 Fertility, pregnancy and lactation**

##### Women of childbearing potential/Contraception

Women of childbearing potential receiving Hemlibra should use effective contraception during, and for at least 6 months after cessation of Hemlibra treatment (see section 5.2).

##### Pregnancy

There are no clinical studies of emicizumab use in pregnant women. Animal reproduction studies have not been conducted with Hemlibra. It is not known whether emicizumab can cause fetal harm when administered to a pregnant woman or can affect reproductive capacity. Hemlibra should be used during pregnancy only if the potential benefit for the mother outweighs the potential risk to the fetus taking into account that, during pregnancy and after parturition, the risk for thrombosis is increased and that several pregnancy complications are linked to an increased risk for disseminated intravascular coagulation (DIC).

##### Breast-feeding

It is not known whether emicizumab is excreted in human milk. No studies have been conducted to assess the impact of emicizumab on milk production or its presence in breast milk. Human IgG is known to be present in human milk. A decision must be made whether to discontinue breast-feeding or to discontinue/abstain from Hemlibra therapy taking into account the benefit of breast-feeding for the child and the benefit of therapy for the woman.

##### Fertility

Animal studies do not indicate direct or indirect harmful effects with respect to reproductive toxicity (see section 5.3). No fertility data are available in humans. Thus, the effect of emicizumab on male and female fertility is unknown.

#### **4.7 Effects on ability to drive and use machines**

Hemlibra has no influence on the ability to drive and use machines.

#### **4.8 Undesirable effects**

##### Summary of the safety profile

The most serious adverse drug reactions (ADRs) reported from the clinical trials with Hemlibra were thrombotic microangiopathy (TMA) and thrombotic events, including cavernous sinus thrombosis (CST) and superficial vein thrombosis contemporaneous with skin necrosis (see below and section 4.4).

The most common ADRs reported in  $\geq 10\%$  of patients treated with at least one dose of Hemlibra were: injection site reactions (19%), headache (15%) and arthralgia (10%).

In total four patients (2.1%) in the clinical trials receiving Hemlibra prophylaxis withdrew from



treatment due to ADRs, which were TMA, skin necrosis and superficial thrombophlebitis, and injection site reaction.

Tabulated list of adverse drug reactions

The following adverse drug reactions (ADRs) are based on pooled data from two phase III clinical trials (Study BH29884 and Study BH29992) and one phase I/II clinical trial (Study ACE002JP), in which a total of 189 male patients with haemophilia A received at least one dose of Hemlibra as routine prophylaxis. Ninety-four patients (50%) were adults. Seven out of the 189 patients (4%) included in the safety population were patients without FVIII inhibitors from the phase I/II clinical trial. The median duration of exposure across the studies was 38 weeks (range: 0.8 to 177.2 weeks).

ADRs from clinical trials in patients who received Hemlibra are listed by MedDRA system organ class (Table 2). The corresponding frequency categories for each ADR are based on the following convention: very common ( $\geq 1/10$ ), common ( $\geq 1/100$  to  $< 1/10$ ), uncommon ( $\geq 1/1,000$  to  $< 1/100$ ), rare ( $\geq 1/10,000$  to  $< 1/1,000$ ), very rare ( $< 1/10,000$ ) and not known (cannot be estimated from the available data).

**Table 2 Summary of adverse drug reactions from pooled clinical trials with Hemlibra**

System Organ Class (SOC)	Adverse reactions (preferred term, MedDRA)	Frequency
Infections and infestations	Cavernous sinus thrombosis	Uncommon
Blood and lymphatic system disorders	Thrombotic microangiopathy	Common
Nervous system disorders	Headache	Very common
Vascular disorders	Thrombophlebitis superficial	Uncommon
Gastrointestinal disorders	Diarrhoea	Common
Skin and subcutaneous tissue disorders	Skin necrosis	Uncommon
Musculoskeletal and connective tissue disorders	Arthralgia	Common
	Myalgia	Common
General disorders and administration site conditions	Injection site reaction	Very common
	Pyrexia	Common

Description of selected adverse drug reactions

*Thrombotic microangiopathy*

Thrombotic microangiopathy (TMA) events were reported in 1.6 % of patients (3/189) from clinical trials and in 8.3% of patients (3/36) who received at least one dose of aPCC while being treated with emicizumab. All 3 TMAs occurred when on average a cumulative amount of  $> 100$  U/Kg/24 hours of aPCC for 24 hours or more was administered during a treatment event (see section 4.4). Patients presented with thrombocytopenia, microangiopathic hemolytic anemia, and acute kidney injury, without severe deficiencies in ADAMTS13 activity.

*Thrombotic events*

Serious thrombotic events were reported in 1.1% of patients (2/189) from clinical trials and in 5.6% of patients (2/36) who received at least one dose of aPCC while being treated with emicizumab. Both serious thrombotic events occurred when on average a cumulative amount of  $> 100$  U/Kg/24 hours of aPCC for 24 hours or more was administered during a treatment event (see section 4.4).

### *Characterization of the interaction between emicizumab and aPCC treatment in pivotal clinical trials*

There were 79 instances of aPCC treatment in patients receiving emicizumab prophylaxis, of which eight instances (10.1%) consisted of on average a cumulative amount of >100 U/kg/24 hours of aPCC for 24 hours or more; two of the eight were associated with thrombotic events and three of the eight were associated with TMA (Table 3). No TMA or thrombotic events were associated with the remaining instances of aPCC treatment. Of all instances of aPCC treatment, 67.1% consisted of only one infusion < 100 U/kg.

**Table 3 Characterisation of aPCC treatment\* in studies BH29884 and BH29992**

Duration of aPCC treatment	Average cumulative amount of aPCC over 24 hours (U/kg/24 hours)		
	<50	50–100	>100
<24 hours	6	47	13
24-48 hours	0	3	1 <sup>b</sup>
>48 hours	1	1	7 <sup>a,a,a,b</sup>

\* An instance of aPCC treatment is defined as all doses of aPCC received by a patient, for any reason, until there was a 36-hour treatment-free break.

<sup>a</sup> Thrombotic microangiopathy

<sup>b</sup> Thrombotic event

### *Injection site reactions*

Injection site reactions (ISRs) were reported very commonly from clinical trials. All ISRs observed in the Hemlibra clinical trials were reported as being non-serious and generally mild to moderate in intensity. Most ISRs resolved without treatment. The most commonly reported ISR symptoms were injection site erythema (7.4 %), injection site pruritus (5.3%) and injection site pain (5.3%).

### Paediatric population

The paediatric population studied comprises a total of 95 patients, of which 2 (2%) were infants (1 months to less than 2 years of age), 55 (58%) were children (from 2 to less than 12 years of age) and 38 (40%) were adolescents (from 12 to less than 18 years old).

The safety profile of Hemlibra was overall consistent between infants, children, adolescents, and adults.

### Reporting of suspected adverse reactions

Reporting suspected adverse reactions after authorisation of the medicinal product is important. It allows continued monitoring of the benefit/risk balance of the medicinal product. Healthcare professionals are asked to report any suspected adverse reactions via the national reporting system listed in Appendix V.

## **4.9 Overdose**

There is limited experience with overdose of Hemlibra.

### Symptoms

Accidental overdose may result in hypercoagulability.

## Management

Patients who receive an accidental overdose should immediately contact their physician and be monitored closely.

## **5. PHARMACOLOGICAL PROPERTIES**

### **5.1 Pharmacodynamic properties**

Pharmacotherapeutic group: antihemorrhagics, other systemic hemostatics; ATC code: B02BX06

#### Mechanism of action

Emicizumab bridges activated factor IX and factor X to restore the function of missing activated factor VIII that is needed for effective haemostasis.

Emicizumab has no structural relationship or sequence homology to factor VIII and, as such, does not induce or enhance the development of direct inhibitors to factor VIII.

#### *Pharmacodynamics*

Prophylactic therapy with Hemlibra shortens the aPTT and increases the reported factor VIII activity (using a chromogenic assay with human coagulation factors). These two pharmacodynamic markers do not reflect the true haemostatic effect of emicizumab *in vivo* (aPTT is overly shortened and reported factor VIII activity may be overestimated) but provide a relative indication of the pro-coagulant effect of emicizumab.

#### Clinical efficacy and safety

##### *Patients (aged 12 to 75 years old) with haemophilia A with factor VIII inhibitors (Study BH29884)*

Hemlibra prophylaxis was evaluated in a randomised, multicentre, open-label clinical study in 109 adolescent and adult males (aged 12 to 75 years old) with haemophilia A with factor VIII inhibitors who had previously received either episodic or prophylactic treatment with bypassing agents (aPCC and rFVIIa). In the study, patients received weekly Hemlibra prophylaxis (Arms A, C, and D) — 3 mg/kg once weekly for 4 weeks followed by 1.5 mg/kg once weekly thereafter — or no prophylaxis (Arm B). Dose up-titration to 3 mg/kg once weekly was allowed after 24 weeks on Hemlibra prophylaxis in case of suboptimal efficacy (i.e.  $\geq 2$  spontaneous and clinically significant bleeds). During the study, two patients underwent up-titration of their maintenance dose to 3 mg/kg once weekly.

Fifty-three patients previously treated with episodic (on-demand) bypassing agents were randomised in a 2:1 ratio to receive Hemlibra prophylaxis (Arm A) or no prophylaxis (Arm B), with stratification by prior 24-week bleed rate ( $< 9$  or  $\geq 9$ ). Patients randomised to Arm B could switch to Hemlibra after completing at least 24 weeks without prophylaxis.

Forty-nine patients previously treated with prophylactic bypassing agents were enrolled in Arm C to receive Hemlibra prophylaxis. Patients previously treated with episodic (on-demand) bypassing agents who had participated in the non-interventional study (NIS) prior to enrolment but were unable to enroll in Study BH29884 prior to the closure of Arms A and B were enrolled in Arm D to receive Hemlibra prophylaxis. The NIS is an observational study with the main objective of capturing detailed clinical data on the bleeding episodes and haemophilia medication use of patients with haemophilia A outside of an interventional trial setting.

The primary objective of the study was to evaluate, among patients previously treated with episodic (on-demand) bypassing agents, the treatment effect of weekly Hemlibra prophylaxis compared with no

prophylaxis (Arm A vs. Arm B) on the number of bleeds requiring treatment with coagulation factors over time (minimum of 24 weeks or date of discontinuation). Other secondary objectives of the randomised comparison of Arms A and B were the efficacy of weekly Hemlibra prophylaxis in reducing the number of all bleeds, spontaneous bleeds, joint bleeds and target joint bleeds, as well as assessing patients' health-related quality of life and health status. The mean exposure time (+SD) for all patients on study was 21.38 weeks (12.01). For each treatment arm, the mean exposure times (+SD) were 28.86 weeks (8.37) for Arm A, 8.79 (3.62) for Arm B, 21.56 (11.85) for Arm C and 7.08 (3.89) for Arm D. One patient in Arm A withdrew from study prior to initiation of Hemlibra.

The study also evaluated the efficacy of weekly Hemlibra prophylaxis compared with previous episodic (on-demand) and prophylactic bypassing agents (separate comparisons) in patients who had participated in the NIS prior to enrolment (Arms A and C, respectively). Only patients from the NIS were included in this comparison, because bleed and treatment data were collected with the same level of granularity in both periods.

In Study BH29884, all primary and secondary objectives were met (see below Tables 4 and 5).

**Table 4 Study BH29884: Overview of efficacy (Intent-To-Treat population)**

<b>Endpoint</b>	<b>Arm B: no prophylaxis</b>	<b>Arm A: 1.5 mg/kg Hemlibra weekly</b>
	N=18	N=35
<b>Treated bleeds</b>		
ABR (95% CI)	23.3 (12.33; 43.89)	2.9 (1.69; 5.02)
% reduction (RR), p-value	87% (0.13), < 0.0001	
% patients with 0 bleeds (95% CI)	5.6 (0.1; 27.3)	62.9 (44.9; 78.5)
Median ABR (IQR)	18.8 (12.97;35.08)	0 (0; 3.73)
<b>All bleeds</b>		
ABR (95% CI)	28.3 (16.79; 47.76)	5.5 (3.58; 8.60)
% reduction (RR), p-value	80% (0.20), < 0.0001	
% patients with 0 bleeds (95% CI)	5.6 (0.1; 27.3)	37.1 (21.5; 55.1)
<b>Treated spontaneous bleeds</b>		
ABR (95% CI)	16.8 (9.94; 28.30)	1.3 (0.73; 2.19)
% reduction (RR), p-value	92% (0.08), < 0.0001	
% patients with 0 bleeds (95% CI)	11.1 (1.4; 34.7)	68.6 (50.7; 83.1)
<b>Treated joint bleeds</b>		
ABR (95% CI)	6.7 (1.99; 22.42)	0.8 (0.26; 2.20)
% reduction (RR), p-value	89% (0.11), 0.0050	
% patients with 0 bleeds (95% CI)	50.0 (26.0; 74.0)	85.7 (69.7; 95.2)
<b>Treated target joint bleeds</b>		
ABR (95% CI)	3.0 (0.96; 9.13)	0.1 (0.03; 0.58)
% reduction (RR), p-value	95% (0.05), 0.0002	
% patients with 0 bleeds (95% CI)	50.0 (26.0; 74.0)	94.3 (80.8; 99.3)
Rate ratio, and confidence interval (CI) come from negative binomial regression (NBR) model and p-value from Stratified Wald test, comparing bleed rate between specified arms.		
Arm B: includes no prophylaxis period only.		
Bleed definitions adapted based on ISTH criteria.		
Treated bleeds = bleeds treated with bypassing agents.		
All bleeds = bleeds treated and not treated with bypassing agents.		
Includes data before up-titration only, for patients whose dose was up-titrated.		
Patients exposed to emicizumab started with a loading dose of 3 mg/kg/week for 4 weeks.		
ABR= Annualised Bleed Rate; CI= confidence interval; RR= rate ratio; IQR= interquartile range, 25 <sup>th</sup> percentile to 75 <sup>th</sup> percentile.		

In the intra-patient analysis, Hemlibra prophylaxis resulted in statistically significant ( $p = 0.0003$ ) and clinically meaningful reduction (79%) in bleed rate for treated bleeds compared with previous bypassing agent prophylaxis collected in the NIS prior to enrolment (see Table 5).

**Table 5 Study BH29884: Annualised Bleed Rate for Hemlibra prophylaxis intra-patient comparison – treated bleeds (NIS patients)**

Endpoint	Arm C <sub>NIS</sub> : previous treatment with prophylactic bypassing agent	Arm C: Hemlibra 1.5 mg/kg weekly
	N=24	N=24
<b>Treated bleeds</b>		
ABR (95% CI)	15.7 (11.08; 22.29)	3.3 (1.33; 8.08)
% patients with 0 bleeds (95% CI)	12.5 (2.7; 32.4)	70.8 (48.9; 87.4)
Median ABR (IQR)	12.0 (5.73; 24.22)	0.0 (0.00; 2.23)
% reduction (RR), p-value	79% (0.21), 0.0003	
Rate ratio and confidence interval (CI) comes from negative binomial regression (NBR) model and p-value from Stratified Wald test, comparing ABR between specified arms. Intra-patient comparator data from the NIS. Only patients who participated in the NIS and in study BH29884 are included. Includes data before up-titration only, for patients whose dose was up-titrated. Treated bleeds = bleeds treated with bypassing agents. Bleed definitions adapted based on ISTH criteria. ABR= Annualised Bleed Rate; CI= confidence interval; RR= rate ratio; IQR=interquartile range, 25 <sup>th</sup> percentile to 75 <sup>th</sup> percentile		

In Study BH29884, health-related quality of life for patients aged  $\geq 18$  years was evaluated at Week 25 based on the *Haemophilia-specific Quality of Life* (Haem-A-QoL) questionnaire for adults. Baseline Total Scores (mean = 41.14 and 44.58, respectively) and Physical Health scale scores (mean = 52.41 and 57.19, respectively) were similar for Hemlibra prophylaxis and no prophylaxis. Table 6 provides a summary of the comparison between the Hemlibra prophylaxis arm (Arm A) and the no prophylaxis arm (Arm B) on the Haem-A-QoL Total Score and Physical Health scale after 24 weeks of treatment adjusting for baseline. Weekly Hemlibra prophylaxis showed a statistically significant and clinically meaningful improvement compared with the no prophylaxis in the pre-specified endpoints of Haem-A-QoL Total Score and Physical Health Scale score at the Week 25 assessment.

**Table 6 Study BH29884: Haem-A-QoL Scores in patients  $\geq 18$  years after 24 weeks**

Haem-A-QoL scores after 24 weeks	Arm B: no prophylaxis (n=14)	Arm A: 1.5 mg/kg Hemlibra weekly (n=25)
<b>Total score</b>		
Adjusted mean	43.21	29.2
Difference in adjusted means (95% CI)	14.01 (5.56, 22.45)	
p-value	0.0019	
<b>Physical health</b>		
Adjusted mean	54.17	32.61
Difference in adjusted means (95% CI)	21.55 (7.89, 35.22)	
p-value	0.0029	
Arm B: includes no prophylaxis period only. Includes data before up-titration only, for patients whose dose was up-titrated. Patients exposed to emicizumab started with a loading dose of 3 mg/kg/week for 4 weeks. Haem-A_QoL scales range from 0 to 100; lower scores are reflective of better HRQoL. Clinically meaningful difference: Total score: 7 points; Physical Health: 10 points.		

In Study BH29884, patients' health status was assessed according to the *EuroQoL Five-Dimension-Five Levels Questionnaire* (EQ-5D-5L). Table 7 provides a summary of the comparison between the Hemlibra prophylaxis arm (Arm A) and the no prophylaxis arm (Arm B) on the EQ-5D-5L index utility scale and visual analog scale after 24 weeks of treatment adjusting for baseline. Weekly Hemlibra showed a statistically significant and clinically meaningful improvement compared with no prophylaxis in the pre specified endpoints of EQ-5D-5L index utility scale and visual analogue scale at the Week 25 assessment.

**Table 7 Study BH29884: EQ-5D-5L scores in patients  $\geq 12$  years after 24 weeks**

EQ-5D-5L scores after 24 weeks	Arm B: no prophylaxis (n=16)	Arm A: 1.5 mg/kg Hemlibra weekly (n=29)
<b>Visual Analogue Scale</b>		
Adjusted mean	74.36	84.08
Difference in adjusted means (95% CI)	-9.72 (-17.62, -1.82)	
p-value	0.0171	
<b>Index Utility Score</b>		
Adjusted mean	0.65	0.81
Difference in adjusted means (95% CI)	-0.16 (-0.25, -0.07)	
p-value	0.0014	
Arm B: includes no prophylaxis period only. Includes data before up-titration only, for patients whose dose was up-titrated. Patients exposed to emicizumab started with a loading dose of 3 mg/kg/week for 4 weeks. Higher scores indicate better quality of life.		
Clinically meaningful difference: VAS: 7 points, Index Utility Score: 0.07 points		

*Paediatric patients (age < 12 years old, or 12 to 17 years old weighing < 40 kg) with haemophilia A with factor VIII inhibitors (Study BH29992) (Interim Analysis)*

Hemlibra weekly prophylaxis was evaluated in a single-arm, multicentre, open-label clinical study in paediatric patients (age < 12 years old, or 12 to 17 years old weighing < 40 kg) with haemophilia A with factor VIII inhibitors. Patients received Hemlibra prophylaxis at 3 mg/kg once weekly for the first 4 weeks followed by 1.5 mg/kg once weekly thereafter.

The study evaluated the pharmacokinetics, safety, and efficacy including the efficacy of weekly Hemlibra prophylaxis compared with previous episodic and prophylactic bypassing agent treatment in patients who had participated in the NIS prior to enrolment (intra-patient comparison).

At the time of the interim analysis, the clinical study had enrolled 60 male patients. Two patients aged < 2 years old, 17 patients aged 2 to < 6 years, 38 patients aged 6 to < 12 years and 3 patients aged ≥ 12 years, resulting in 57 patients that were < 12 years old and evaluable for efficacy. The annualized bleed rate and percent of patients with zero bleeds were calculated for 23 patients < 12 years old who received weekly Hemlibra prophylaxis for at least 12 weeks (see Table 7). The median observation time for these patients was 38.1 weeks (range: 12.7 to 41.6 weeks).

The interim analysis efficacy results for Study BH29992 are summarised below (see Tables 8 and 9). In total 20 of 23 (87%) patients had zero treated bleeds and 8 of 23 (34.8%) did not have any bleeds while receiving Hemlibra prophylaxis (see Table 8).

**Table 8 Study BH29992: Overview of efficacy (interim analysis)**

<b>Endpoint</b>	<b>ABR (95% CI) N = 23</b>	<b>Median ABR (IQR) N = 23</b>	<b>% Zero Bleeds (95% CI) N = 23</b>
Treated bleeds	0.2 (0.06; 0.62)	0 (0; 0)	87 (66.4; 97.2)
All bleeds	2.9 (1.75; 4.94)	1.5 (0; 4.53)	34.8 (16.4; 57.3)
Treated spontaneous bleeds	0.1 (0.01; 0.47)	0 (0; 0)	95.7 (78.1; 99.9)
Treated joint bleeds	0.1 (0.01; 0.47)	0 (0; 0)	95.7 (78.1; 99.9)
Treated target joint bleeds	Not Estimable*	0 (0; 0)	100 (85.2; 100)

\*No treated target joint bleeds reported

ABR = annualized bleed rate; CI = confidence interval; IQR = interquartile range, 25th percentile to 75th percentile

In the intra-patient analysis, Hemlibra weekly prophylaxis resulted in a clinical meaningful reduction (99%) in treated bleed rate in thirteen paediatric patients after at least 12 weeks of treatment compared to their bleed rate collected in the NIS prior to enrolment.

**Table 9 Study BH29992: Annualised Bleed Rate for Hemlibra prophylaxis intra-patient comparison in paediatric patients < 12 years of age (interim analysis) – treated bleeds (NIS patients)**

Endpoint	Previous bypassing agent treatment* (N = 13)	Hemlibra prophylaxis (N = 13)
<b>Treated bleeds</b>		
ABR (95% CI)	17.2 (12.38; 23.76)	0.2 (0.06; 0.76)
% reduction RR (95% CI)	99% 0.01 (0.004; 0.044)	
% patients with zero bleeds (95% CI)	7.7 (0.2; 36)	84.6 (54.6; 98.1)
Median ABR (IQR)	14.3 (11.02; 24.35)	0 (0; 0)

ABR = annualized bleed rate; CI = confidence interval; RR = rate ratio

\* Previous prophylactic treatment for 12 patients; previous episodic (on-demand) treatment for 1 subject

There is limited experience with bypassing agent use during surgeries and procedures. Bypassing agent use during surgeries and procedures was determined by the investigator.

#### Immunogenicity

As with all therapeutic proteins, there is the potential for an immune response in patients treated with emicizumab. A total of 189 patients were tested for anti-emicizumab antibodies in the clinical trials. Four patients (2.1%) tested positive for anti-emicizumab antibodies in the phase I/II trials, all of which were non-neutralising.

The data reflect the number of patients whose test results were considered positive for antibodies to emicizumab using an enzyme-linked immunosorbent assay (ELISA). Immunogenicity assay results may be influenced by several factors including assay sensitivity and specificity, sample handling, timing of sample collection, concomitant medicinal products and underlying disease. For these reasons, comparison of incidence of antibodies to emicizumab with the incidence of antibodies to other products may be misleading.

In case of clinical signs of loss of efficacy, a change of treatment should be considered.

#### Paediatric population

The European Medicines Agency has deferred the obligation to submit the results of studies with Hemlibra in one or more subsets of the paediatric population in the treatment of hereditary factor VIII deficiency (see section 4.2 for information on paediatric use).

### **5.2 Pharmacokinetic properties**

The pharmacokinetics of emicizumab was determined via non-compartmental analysis in healthy subjects and using a population pharmacokinetic analysis on a database composed of 141 patients with haemophilia A.

#### Absorption

Following subcutaneous administration in haemophilia A patients, the absorption half-life was 1.7 days.



Following multiple subcutaneous administrations of 3 mg/kg once weekly for the first 4 weeks in haemophilia A patients, mean ( $\pm$ SD) trough plasma concentrations of emicizumab increased to achieve  $54.6 \pm 14.3$   $\mu\text{g/mL}$  at Week 5. Trough plasma concentrations of approximately 50  $\mu\text{g/mL}$  were sustained thereafter with weekly dosing of 1.5 mg/kg (Figure 1).

**Figure 1** Studies BH29884 (adult and adolescent study) and BH29992 (paediatric study): mean emicizumab trough plasma concentrations ( $\mu\text{g/mL}$ )

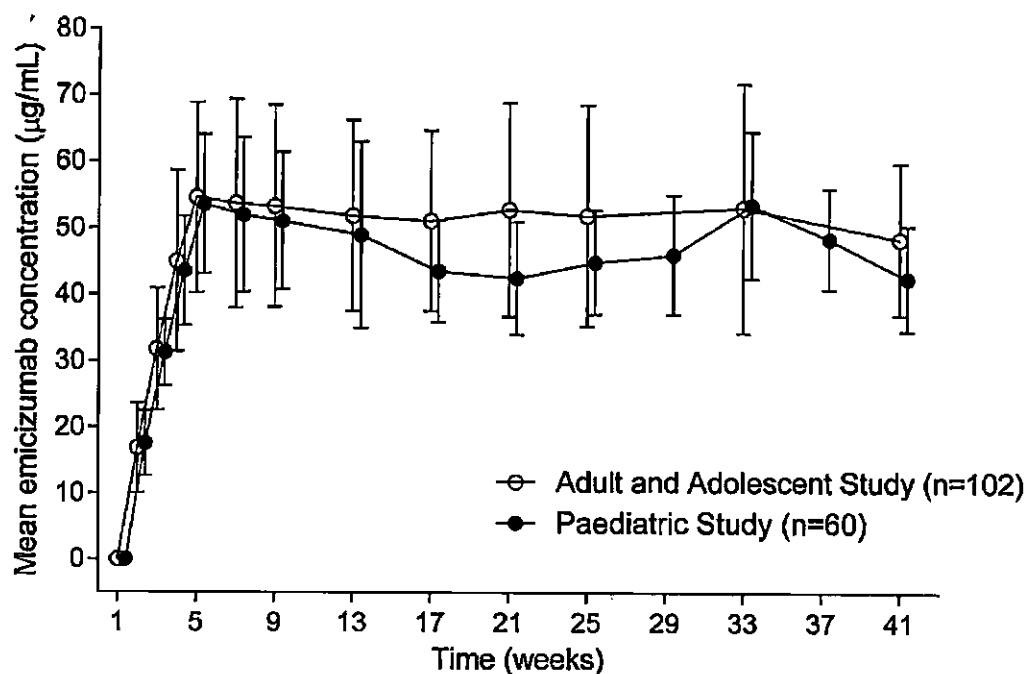

The predicted mean ( $\pm$ SD)  $C_{\text{trough}}$  and  $C_{\text{max}}$  at steady state were  $52.2 \pm 13.5$   $\mu\text{g/mL}$  and  $56.5 \pm 13.5$   $\mu\text{g/mL}$ , respectively. The mean ( $\pm$ SD) ratio of  $C_{\text{max}}/C_{\text{trough}}$  at steady state was  $1.07 \pm 0.03$ .

In healthy subjects, the absolute bioavailability following subcutaneous administration of 1 mg/kg was between 80.4% and 93.1% depending on the injection site. Similar pharmacokinetic profiles were observed following subcutaneous administration in the abdomen, upper arm, and thigh. Emicizumab can be administered interchangeably at these anatomical sites (see section 4.2).

#### Distribution

Following a single intravenous dose of 0.25 mg/kg emicizumab in healthy subjects, the volume of distribution at steady state was 106 mL/kg (i.e. 7.4 L for a 70-kg adult).

The apparent volume of distribution ( $V/F$ ), estimated from the population PK analysis, in haemophilia A patients following multiple subcutaneous doses of emicizumab was 11.4 L.

#### Metabolism

The metabolism of emicizumab has not been studied. IgG antibodies are mainly catabolised by lysosomal proteolysis and then eliminated from or reused by the body.

#### Elimination

Following intravenous administration of 0.25 mg/kg in healthy subjects, the total clearance of emicizumab was 3.26 mL/kg/day (i.e. 0.228 L/d for a 70-kg adult) and the mean terminal half-life was 26.7 days.

Following single subcutaneous injection in healthy subjects, the elimination half-life was approximately 4 to 5 weeks.

Following multiple subcutaneous injections in haemophilia A patients, the apparent clearance was 0.244 L/day and the elimination apparent half-life was 27.8 days.

#### Dose linearity

Emicizumab exhibited dose-proportional pharmacokinetics in patients with haemophilia A over a dose range from 0.3 to 3 mg/kg once weekly following subcutaneous administration.

#### Special populations

##### *Paediatric*

The effect of age on the pharmacokinetics of emicizumab was assessed in a population pharmacokinetic analysis which included 59 children (less than 12 years) and 38 adolescents (12 to 17 years) with haemophilia A. An additional descriptive analysis of pharmacokinetic data collected from Study BH29992 was performed in two infants (1 month to < 2 years), 55 children ( $\geq 2$  years to < 12 years) and 3 adolescents (12 to 17 years).

Age did not affect the pharmacokinetics of emicizumab in paediatric patients.

##### *Elderly*

The effect of age on the pharmacokinetics of emicizumab was assessed in a population pharmacokinetic analysis which included three subjects aged 65 years and older (no subjects were older than 75 years of age). Clearance increased with older age, but no clinically important differences were observed in the pharmacokinetics of emicizumab between subjects < 65 years and subjects  $\geq 65$  years.

##### *Race*

Population pharmacokinetics analyses in patients with haemophilia A showed that race did not affect the pharmacokinetics of emicizumab. No dose adjustment is required for this demographic factor.

##### *Renal impairment*

No dedicated studies of the effect of renal impairment on the pharmacokinetics of emicizumab have been conducted.

The safety and efficacy of emicizumab have not been specifically tested in patients with renal impairment. There are limited data available on the use of Hemlibra in patients with mild renal impairment. No data are available on the use of Hemlibra in patients with moderate to severe renal impairment. Mild renal impairment did not affect the pharmacokinetics of emicizumab.

Emicizumab is a monoclonal antibody and is cleared via catabolism rather than renal excretion and a change in dose is not expected to be required for patients with renal impairment.

##### *Hepatic impairment*

No dedicated studies on the effect of hepatic impairment on the pharmacokinetics of emicizumab have been conducted. Most of the patients with haemophilia A in the population pharmacokinetic analysis had normal hepatic function (bilirubin and AST  $\leq$  ULN, n=113) or mild hepatic impairment (bilirubin  $\leq$  ULN and AST > ULN or bilirubin < 1.0 to 1.5  $\times$  ULN and any AST, n=17). Mild hepatic impairment did not affect the pharmacokinetics of emicizumab (see section 4.2). The safety and

efficacy of emicizumab have not been specifically tested in patients with hepatic impairment. Patients with mild and moderate hepatic impairment were included in clinical trials. No data are available on the use of Hemlibra in patients with severe hepatic impairment.

Emicizumab is a monoclonal antibody and cleared via catabolism rather than hepatic metabolism and a change in dose is not expected to be required for patients with hepatic impairment.

### **5.3 Preclinical safety data**

Preclinical data reveal no special hazards for humans based on studies of acute and repeated dose toxicity, including safety pharmacology endpoints and endpoints for reproductive toxicity.

#### Fertility

Emicizumab did not cause any changes in the reproductive organs of male or female cynomolgus monkeys up to the highest tested dose of 30 mg/kg/week (equivalent to 11 times the human exposure at the highest dose of 3 mg/kg/week, based on AUC).

#### Teratogenicity

No data are available with respect to potential side effects of emicizumab on embryo-foetal development.

#### Injection site reactions

Reversible hemorrhage, perivascular mononuclear cell infiltration, degeneration/necrosis of subcutis and swelling of endothelium in the subcutis was noted in animals after subcutaneous injection.

## **6. PHARMACEUTICAL PARTICULARS**

### **6.1 List of excipients**

L-Arginine  
L-Histidine  
L-Aspartic acid  
Poloxamer 188  
Water for injections

### **6.2 Incompatibilities**

No incompatibilities between Hemlibra and polypropylene or polycarbonate syringes and stainless steel needles have been observed.

In the absence of compatibility studies, this medicinal product must not be mixed with other medicinal products.

### **6.3 Shelf life**

#### Unopened vial

2 years.

Once removed from the refrigerator, unopened vials can be kept at room temperature (below 30°C) for up to 7 days.

After storage at room temperature, unopened vials may be returned to the refrigerator. If stored out of and then returned to refrigeration, the total combined time out of refrigeration should not exceed 7 days. The vials should never be exposed to temperatures above 30 °C. Vials that have been kept at room temperature for more than 7 days or exposed to temperatures above 30 °C should be discarded.

#### Pierced vial and filled syringe

From a microbiological point of view, once transferred from the vial to the syringe, the medicinal product should be used immediately. If not used immediately, in-use storage times and conditions are the responsibility of the user.

### **6.4 Special precautions for storage**

Store in a refrigerator (2°C to 8°C).

Do not freeze.

Keep the vial in the outer carton in order to protect from light.

For storage conditions after first opening of the medicinal product, see section 6.3.

### **6.5 Nature and contents of container**

#### Hemlibra 30 mg/mL solution for injection

3 mL clear glass type I vial with butyl rubber stopper laminated with a fluoro-resin film and crimped with an aluminium cap fitted with a plastic flip-off disk. Each vial contains 30 mg emicizumab in 1 mL of solution for injection. Each carton contains one vial.

#### Hemlibra 150 mg/mL solution for injection

3 mL clear glass type I vial with butyl rubber stopper laminated with a fluoro-resin film and crimped with an aluminium cap fitted with a plastic flip-off disk. Each vial contains 60 mg emicizumab in 0.4 mL of solution for injection. Each carton contains one vial.

3 mL clear glass type I vial with butyl rubber stopper laminated with a fluoro-resin film and crimped with an aluminium cap fitted with a plastic flip-off disk. Each vial contains 105 mg emicizumab in 0.7 mL of solution for injection. Each carton contains one vial.

3 mL clear glass type I vial with butyl rubber stopper laminated with a fluoro-resin film and crimped with an aluminium cap fitted with a plastic flip-off disk. Each vial contains 150 mg emicizumab in 1 mL of solution for injection. Each carton contains one vial.

Not all pack sizes may be marketed.

### **6.6 Special precautions for disposal and other handling**

Hemlibra solution is a sterile, preservative-free, and ready to use solution for subcutaneous injection that does not need to be diluted.

Hemlibra should be inspected visually to ensure there is no particulate matter or discolouration prior to administration. Hemlibra is a colourless to slightly yellow solution. The solution should be discarded if particulate matter is visible or product is discoloured.

Do not shake.

Hemlibra solution for injection vials are for single-use only.

A syringe, a transfer needle and an injection needle are needed to withdraw Hemlibra solution from the vial and inject it subcutaneously (please see below recommended features).

A 1 mL syringe should be used for an injection up to 1 mL of Hemlibra solution, whereas a 2 to 3 mL syringe should be used for an injection greater than 1 mL and up to 2 mL.

Refer to the Hemlibra "Instructions for Use" for handling instructions when combining vials in a syringe. Different Hemlibra vial concentrations (30 mg/mL and 150 mg/mL) should not be used when combining vials to administer the prescribed dose.

#### 1 mL syringe

Criteria: Transparent polypropylene or polycarbonate syringe with Luer-lock tip, graduation 0.01 mL.

#### 2 to 3 mL syringe

Criteria: Transparent polypropylene or polycarbonate syringe with Luer-lock tip, graduation 0.1 mL.

#### Transfer needle

Criteria: Stainless steel with Luer-lock connection, gauge 18 G, length 35mm (1½"), preferably semi-blunted tip.

#### Injection needle

Criteria: Stainless steel with Luer-lock connection, gauge 26 G, length preferably 9 mm (3/8") or maximally 13mm (½"), preferably including needle safety feature.

Please see section 4.2 and package leaflet (section 7 Instructions for Use), for additional information on administration.

Any unused medicinal product or waste material should be disposed of in accordance with local requirements.

## **7. MARKETING AUTHORISATION HOLDER**

Roche Registration Limited  
6 Falcon Way  
Shire Park  
Welwyn Garden City  
AL7 1TW  
United Kingdom

## **8. MARKETING AUTHORISATION NUMBER(S)**

EU/1/18/1271/001 (30 mg/1 ml)  
EU/1/18/1271/002 (60 mg/0.4 ml)  
EU/1/18/1271/003 (105 mg/0.7 ml)  
EU/1/18/1271/004 (150 mg/1 ml)

**9. DATE OF FIRST AUTHORISATION/RENEWAL OF THE AUTHORISATION**

**10. DATE OF REVISION OF THE TEXT**

Detailed information on this medicinal product is available on the website of the European Medicines Agency <http://www.ema.europa.eu>.

## **ANNEX II**

- A. MANUFACTURER OF THE BIOLOGICAL ACTIVE SUBSTANCE AND MANUFACTURERS RESPONSIBLE FOR BATCH RELEASE**
- B. CONDITIONS OR RESTRICTIONS REGARDING SUPPLY AND USE**
- C. OTHER CONDITIONS AND REQUIREMENTS OF THE MARKETING AUTHORISATION**
- D. CONDITIONS OR RESTRICTIONS WITH REGARD TO THE SAFE AND EFFECTIVE USE OF THE MEDICINAL PRODUCT**

**A. MANUFACTURER OF THE BIOLOGICAL ACTIVE SUBSTANCE AND MANUFACTURERS RESPONSIBLE FOR BATCH RELEASE**

Name and address of the manufacturer of the biological active substance

Chugai Pharma Manufacturing Co., Ltd.  
5-1, Ukima 5-Chome  
Kita-Ku, Tokyo  
115-8543  
Japan

Name and address of the manufacturers responsible for batch release

Roche Austria GmbH  
Engelhorngasse 3  
1211 Wien  
Austria

Roche Pharma AG  
Emil-Barell-Strasse 1  
79639 Grenzach-Wyhlen  
Germany

The printed package leaflet of the medicinal product must state the name and address of the manufacturer responsible for the release of the concerned batch.

**B. CONDITIONS OR RESTRICTIONS REGARDING SUPPLY AND USE**

Medicinal product subject to restricted medical prescription.

**C. OTHER CONDITIONS AND REQUIREMENTS OF THE MARKETING AUTHORISATION**

● **Periodic safety update reports**

The requirements for submission of periodic safety update reports for this medicinal product are set out in the list of Union reference dates (EURD list) provided for under Article 107c(7) of Directive 2001/83/EC and any subsequent updates published on the European medicines web-portal.

The marketing authorisation holder shall submit the first periodic safety update report for this product within 6 months following authorisation.

**D. CONDITIONS OR RESTRICTIONS WITH REGARD TO THE SAFE AND EFFECTIVE USE OF THE MEDICINAL PRODUCT**

● **Risk Management Plan (RMP)**

The MAH shall perform the required pharmacovigilance activities and interventions detailed in the agreed RMP presented in Module 1.8.2 of the marketing authorisation and any agreed subsequent updates of the RMP.

An updated RMP should be submitted:

- At the request of the European Medicines Agency;



- Whenever the risk management system is modified, especially as the result of new information being received that may lead to a significant change to the benefit/risk profile or as the result of an important (pharmacovigilance or risk minimisation) milestone being reached.
- **Additional risk minimisation measures**

Prior to launch of Hemlibra in each Member State the Marketing Authorisation Holder (MAH) must agree about the content and format of the educational programme, including communication media, distribution modalities, and any other aspects of the programme, with the National Competent Authority.

The educational programme is aimed at increasing communication and medical and patient education around the important identified risks of thromboembolic events and thrombotic microangiopathy associated with the concomitant use of emicizumab and activated prothrombin complex concentrate (aPCC), and the important potential risk of life-threatening bleeding due to misinterpretation of the standard coagulation tests (unreliable in patients treated with emicizumab) and provide information on how to manage them.

The MAH shall ensure that in each Member State where Hemlibra is marketed, all healthcare professionals, patients/carers who are expected to prescribe, dispense or use Hemlibra, and laboratory professionals, have access to/are provided with the following educational package:

- Physician educational material
- Patient/Carer educational material
- Laboratory professionals educational material

**The physician educational material** should contain:

- The Summary of Product Characteristics
- Guide for healthcare professionals
- Patient alert card
- **The guide for healthcare professionals** shall contain the following key elements:
  - Brief introduction to emicizumab (chemical class, mode of action, pharmacodynamics and indication)
  - Relevant information (e.g. seriousness, severity, frequency, time to onset, reversibility as applicable) of the following safety concerns associated with the use of Hemlibra:
    - thromboembolic events associated with the concomitant use of emicizumab and activated prothrombin complex concentrate (aPCC),
    - thrombotic microangiopathy associated with the concomitant use of emicizumab and aPCC
    - life-threatening bleeding due to misinterpretation of the standard coagulation tests (unreliable in patients treated with emicizumab)
  - Guidance on the use of bypassing agents concomitantly with emicizumab, including the following information:
    - Treatment with prophylactic bypassing agents should be discontinued the day before starting emicizumab therapy;
    - Physicians should discuss with all patients and/or caregivers the exact dose and schedule of bypassing agents to use, if required while receiving emicizumab prophylaxis;
    - Emicizumab increases the patient's coagulation potential and the dose and duration of treatment with bypassing agents may require adjustment depending on the location and extent of bleeding and on the patient's clinical conditions;

- For all coagulation agents (aPCC, rFVIIa, FVIII, etc.), consideration should be given to verifying bleeds prior to repeated dosing;
  - Use of aPCC should be avoided unless no other treatment options/alternatives are available and aPCC dosing recommendations in case aPCC is the only option.
  - Treating physicians must carefully weigh the risk of TMA and thromboembolism against the risk of bleeding when considering aPCC treatment.
  - Information on emicizumab's interference with certain laboratory coagulation tests which will affect their reliability in the emicizumab setting and warning that these tests should not be used to monitor for emicizumab activity, determine need for factor replacement dosing, or measure FVIII inhibitors.
  - Information on assays and methods not affected by emicizumab that may be used to monitor coagulation parameters during treatment, with specific considerations for FVIII chromogenic activity assays;
  - Listing of laboratory tests unaffected by emicizumab;
  - Reminder that all patients receiving treatment with emicizumab should be given a Patient Alert Card and reminded to carry it at all times and show it to any healthcare professionals who may treat them and to laboratory professionals that will perform their coagulation testing;
  - Reminder to report any adverse events associated with the use of emicizumab.
- **The patient alert card shall contain the following key messages:**
    - Instructions for patients to carry the card at any time, including in conditions of emergency and to present the card at visits to doctors, hospital clinics, carers, laboratory professionals or pharmacists to inform on emicizumab treatment and risks;
    - Information on serious, life-threatening thromboembolic events or thrombotic microangiopathy events that have been observed with the concomitant use of emicizumab with activated prothrombin complex concentrate (aPCC) in patients on emicizumab prophylaxis;
    - Guidance on the use of bypassing agents concomitantly with emicizumab and on the dosing recommendations for patients requiring treatment with bypassing agents in the perioperative setting;
    - Warning on emicizumab's interference with certain laboratory coagulation tests which will affect their reliability and information that single-factor assays utilizing chromogenic or immuno-based methods are not affected by emicizumab and may be used to monitor coagulation parameters during treatment, with specific consideration for factor VIII chromogenic activity assays;
    - Contact details of the patient's emicizumab prescriber.

**The patient/carer educational material should contain:**

- The package leaflet
- Guide for patients/carers
- **The guide for patients/carers shall contain the following key messages:**
  - What is emicizumab, how emicizumab has been tested, and how to use emicizumab;
  - Warning on the risks associated with the concomitant use of bypassing agents and Hemlibra and to discuss with their doctor if they are receiving activated prothrombin complex concentrate (aPCC) when being prescribed or while receiving Hemlibra;
  - Description of the signs and symptoms of the following safety concerns and reminder of the importance of immediately stopping using Hemlibra and aPCC and notifying their treating physician if symptoms occur :
    - Destruction of red blood cells (thrombotic microangiopathy)
    - Blood clots (thromboembolism)

- Information that they should be given a Patient Alert Card and reminder to carry it at all times and to show it to any healthcare professionals who may treat them;
- Information on emicizumab's interference with certain laboratory coagulation tests which will affect their reliability and on the importance to show the patient alert card to any healthcare professionals who may treat them and to laboratory professionals that will perform their coagulation testing;
- Reminder to report any adverse events to their treating doctor.

**The laboratory professional educational material should contain:**

- The Summary of Product Characteristics
- Guide for Laboratory Professionals
- **The guide for laboratory professionals shall contain the following key messages:**
  - Chemical class, mode of action, pharmacodynamics and indication for emicizumab
  - Information on emicizumab's interference with certain laboratory coagulation tests which will affect their reliability and not accurately reflect the patient's underlying hemostatic status during emicizumab prophylaxis. Warning that these tests should not be used to monitor for emicizumab activity, determine need for factor replacement dosing, or measure FVIII inhibitors;
  - Information on assays and methods not affected by emicizumab and that may be used to monitor coagulation parameters during treatment, with specific considerations for FVIII chromogenic activity assays;
  - Listing of laboratory tests unaffected by emicizumab;
  - Recommendation that the laboratory director contact the patient's treating physician to discuss any abnormal test results.

**ANNEX III**  
**LABELLING AND PACKAGE LEAFLET**

**A. LABELLING**

**PARTICULARS TO APPEAR ON THE OUTER PACKAGING**

**OUTER CARTON**

**1. NAME OF THE MEDICINAL PRODUCT**

Hemlibra 30 mg/mL solution for injection  
emicizumab

**2. STATEMENT OF ACTIVE SUBSTANCE(S)**

Each vial of 1 mL contains 30 mg of emicizumab at a concentration of 30 mg/mL.

**3. LIST OF EXCIPIENTS**

Excipients: L-Arginine, L-Histidine, L-Aspartic acid, Poloxamer 188, water for injections.

**4. PHARMACEUTICAL FORM AND CONTENTS**

Solution for injection

1 vial  
30 mg/1mL

**5. METHOD AND ROUTE(S) OF ADMINISTRATION**

For subcutaneous use  
Read the package leaflet before use  
Do not shake

**6. SPECIAL WARNING THAT THE MEDICINAL PRODUCT MUST BE STORED OUT OF THE SIGHT AND REACH OF CHILDREN**

Keep out of the sight and reach of children

**7. OTHER SPECIAL WARNING(S), IF NECESSARY**

**8. EXPIRY DATE**

EXP

**9. SPECIAL STORAGE CONDITIONS**

Store in a refrigerator  
Do not freeze  
Keep the vial in the outer carton in order to protect from light

**10. SPECIAL PRECAUTIONS FOR DISPOSAL OF UNUSED MEDICINAL PRODUCTS OR WASTE MATERIALS DERIVED FROM SUCH MEDICINAL PRODUCTS, IF APPROPRIATE**

**11. NAME AND ADDRESS OF THE MARKETING AUTHORISATION HOLDER**

Roche Registration Limited  
6 Falcon Way  
Shire Park  
Welwyn Garden City  
AL7 1TW  
United Kingdom

**12. MARKETING AUTHORISATION NUMBER(S)**

EU/1/18/1271/001

**13. BATCH NUMBER**

Batch

**14. GENERAL CLASSIFICATION FOR SUPPLY**

**15. INSTRUCTIONS ON USE**

**16. INFORMATION IN BRAILLE**

hemlibra 30 mg

**17. UNIQUE IDENTIFIER – 2D BARCODE**

2D barcode carrying the unique identifier included

**18. UNIQUE IDENTIFIER - HUMAN READABLE DATA**

PC:  
SN:  
NN:

**MINIMUM PARTICULARS TO APPEAR ON SMALL IMMEDIATE PACKAGING UNITS**  
**VIAL**

**1. NAME OF THE MEDICINAL PRODUCT AND ROUTE(S) OF ADMINISTRATION**

Hemlibra 30 mg/mL solution for injection  
emicizumab  
For subcutaneous use

**2. METHOD OF ADMINISTRATION**

Do not shake.

**3. EXPIRY DATE**

EXP

**4. BATCH NUMBER**

Batch

**5. CONTENTS BY WEIGHT, BY VOLUME OR BY UNIT**

30 mg/1mL

**6. OTHER**



**PARTICULARS TO APPEAR ON THE OUTER PACKAGING**

**OUTER CARTON**

**1. NAME OF THE MEDICINAL PRODUCT**

Hemlibra 150 mg/mL solution for injection  
emicizumab

**2. STATEMENT OF ACTIVE SUBSTANCE(S)**

Each vial of 0.4 mL contains 60 mg of emicizumab at a concentration of 150 mg/mL.

**3. LIST OF EXCIPIENTS**

Excipients: L-Arginine, L-Histidine, L-Aspartic acid, Poloxamer 188, water for injections.

**4. PHARMACEUTICAL FORM AND CONTENTS**

Solution for injection

1 vial  
60 mg/0.4 mL

**5. METHOD AND ROUTE(S) OF ADMINISTRATION**

For subcutaneous use  
Read the package leaflet before use  
Do not shake

**6. SPECIAL WARNING THAT THE MEDICINAL PRODUCT MUST BE STORED OUT OF THE SIGHT AND REACH OF CHILDREN**

Keep out of the sight and reach of children

**7. OTHER SPECIAL WARNING(S), IF NECESSARY**

**8. EXPIRY DATE**

EXP

**9. SPECIAL STORAGE CONDITIONS**

Store in a refrigerator  
Do not freeze  
Keep the vial in the outer carton in order to protect from light

**10. SPECIAL PRECAUTIONS FOR DISPOSAL OF UNUSED MEDICINAL PRODUCTS OR WASTE MATERIALS DERIVED FROM SUCH MEDICINAL PRODUCTS, IF APPROPRIATE**

**11. NAME AND ADDRESS OF THE MARKETING AUTHORISATION HOLDER**

Roche Registration Limited  
6 Falcon Way  
Shire Park  
Welwyn Garden City  
AL7 1TW  
United Kingdom

**12. MARKETING AUTHORISATION NUMBER(S)**

EU/1/18/1271/002

**13. BATCH NUMBER**

Batch

**14. GENERAL CLASSIFICATION FOR SUPPLY**

**15. INSTRUCTIONS ON USE**

**16. INFORMATION IN BRAILLE**

hemlibra 60 mg

**17. UNIQUE IDENTIFIER – 2D BARCODE**

2D barcode carrying the unique identifier included

**18. UNIQUE IDENTIFIER - HUMAN READABLE DATA**

PC:  
SN:  
NN:

**MINIMUM PARTICULARS TO APPEAR ON SMALL IMMEDIATE PACKAGING UNITS**

**VIAL**

**1. NAME OF THE MEDICINAL PRODUCT AND ROUTE(S) OF ADMINISTRATION**

Hemlibra 150 mg/mL solution for injection  
emicizumab  
For subcutaneous use

**2. METHOD OF ADMINISTRATION**

Do not shake.

**3. EXPIRY DATE**

EXP

**4. BATCH NUMBER**

Batch

**5. CONTENTS BY WEIGHT, BY VOLUME OR BY UNIT**

60 mg/0.4 mL

**6. OTHER**

**PARTICULARS TO APPEAR ON THE OUTER PACKAGING**

**OUTER CARTON**

**1. NAME OF THE MEDICINAL PRODUCT**

Hemlibra 150 mg/mL solution for injection  
emicizumab

**2. STATEMENT OF ACTIVE SUBSTANCE(S)**

Each vial of 0.7 mL contains 105 mg of emicizumab at a concentration of 150 mg/mL.

**3. LIST OF EXCIPIENTS**

Excipients: L-Arginine, L-Histidine, L-Aspartic acid, Poloxamer 188, water for injections.

**4. PHARMACEUTICAL FORM AND CONTENTS**

Solution for injection

1 vial  
105 mg/0.7 mL

**5. METHOD AND ROUTE(S) OF ADMINISTRATION**

For subcutaneous use  
Read the package leaflet before use  
Do not shake

**6. SPECIAL WARNING THAT THE MEDICINAL PRODUCT MUST BE STORED OUT OF THE SIGHT AND REACH OF CHILDREN**

Keep out of the sight and reach of children

**7. OTHER SPECIAL WARNING(S), IF NECESSARY**

**8. EXPIRY DATE**

EXP

**9. SPECIAL STORAGE CONDITIONS**

Store in a refrigerator  
Do not freeze  
Keep the vial in the outer carton in order to protect from light

**10. SPECIAL PRECAUTIONS FOR DISPOSAL OF UNUSED MEDICINAL PRODUCTS OR WASTE MATERIALS DERIVED FROM SUCH MEDICINAL PRODUCTS, IF APPROPRIATE**

**11. NAME AND ADDRESS OF THE MARKETING AUTHORISATION HOLDER**

Roche Registration Limited  
6 Falcon Way  
Shire Park  
Welwyn Garden City  
AL7 1TW  
United Kingdom

**12. MARKETING AUTHORISATION NUMBER(S)**

EU/1/18/1271/003

**13. BATCH NUMBER**

Batch

**14. GENERAL CLASSIFICATION FOR SUPPLY**

**15. INSTRUCTIONS ON USE**

**16. INFORMATION IN BRAILLE**

hemlibra 105 mg

**17. UNIQUE IDENTIFIER – 2D BARCODE**

2D barcode carrying the unique identifier included

**18. UNIQUE IDENTIFIER - HUMAN READABLE DATA**

PC:  
SN:  
NN:

**MINIMUM PARTICULARS TO APPEAR ON SMALL IMMEDIATE PACKAGING UNITS**

**VIAL**

**1. NAME OF THE MEDICINAL PRODUCT AND ROUTE(S) OF ADMINISTRATION**

Hemlibra 150 mg/mL solution for injection  
emicizumab  
For subcutaneous use

**2. METHOD OF ADMINISTRATION**

Do not shake

**3. EXPIRY DATE**

EXP

**4. BATCH NUMBER**

Batch

**5. CONTENTS BY WEIGHT, BY VOLUME OR BY UNIT**

105 mg/0.7 mL

**6. OTHER**

**PARTICULARS TO APPEAR ON THE OUTER PACKAGING**

**OUTER CARTON**

**1. NAME OF THE MEDICINAL PRODUCT**

Hemlibra 150 mg/mL solution for injection  
emicizumab

**2. STATEMENT OF ACTIVE SUBSTANCE(S)**

Each vial of 1 mL contains 150 mg of emicizumab at a concentration of 150 mg/mL.

**3. LIST OF EXCIPIENTS**

Excipients: L-Arginine, L-Histidine, L-Aspartic acid, Poloxamer 188, water for injections.

**4. PHARMACEUTICAL FORM AND CONTENTS**

Solution for injection

1 vial  
150 mg/1 mL

**5. METHOD AND ROUTE(S) OF ADMINISTRATION**

For subcutaneous use  
Read the package leaflet before use  
Do not shake

**6. SPECIAL WARNING THAT THE MEDICINAL PRODUCT MUST BE STORED OUT OF THE SIGHT AND REACH OF CHILDREN**

Keep out of the sight and reach of children

**7. OTHER SPECIAL WARNING(S), IF NECESSARY**

**8. EXPIRY DATE**

EXP

**9. SPECIAL STORAGE CONDITIONS**

Store in a refrigerator  
Do not freeze  
Keep the vial in the outer carton in order to protect from light

**10. SPECIAL PRECAUTIONS FOR DISPOSAL OF UNUSED MEDICINAL PRODUCTS OR WASTE MATERIALS DERIVED FROM SUCH MEDICINAL PRODUCTS, IF APPROPRIATE**

**11. NAME AND ADDRESS OF THE MARKETING AUTHORISATION HOLDER**

Roche Registration Limited  
6 Falcon Way  
Shire Park  
Welwyn Garden City  
AL7 1TW  
United Kingdom

**12. MARKETING AUTHORISATION NUMBER(S)**

EU/1/18/1271/004

**13. BATCH NUMBER**

Batch

**14. GENERAL CLASSIFICATION FOR SUPPLY**

**15. INSTRUCTIONS ON USE**

**16. INFORMATION IN BRAILLE**

hemlibra 150 mg

**17. UNIQUE IDENTIFIER – 2D BARCODE**

2D barcode carrying the unique identifier included

**18. UNIQUE IDENTIFIER - HUMAN READABLE DATA**

PC:  
SN:  
NN:



**MINIMUM PARTICULARS TO APPEAR ON SMALL IMMEDIATE PACKAGING UNITS**  
**VIAL**

**1. NAME OF THE MEDICINAL PRODUCT AND ROUTE(S) OF ADMINISTRATION**

Hemlibra 150 mg/mL solution for injection  
emicizumab  
For subcutaneous use

**2. METHOD OF ADMINISTRATION**

Do not shake

**3. EXPIRY DATE**

EXP

**4. BATCH NUMBER**

Batch

**5. CONTENTS BY WEIGHT, BY VOLUME OR BY UNIT**

150 mg/1 mL

**6. OTHER**

**Package leaflet: Information for the user**

**Hemlibra 30 mg/mL solution for injection  
emicizumab**

▼ This medicine is subject to additional monitoring. This will allow quick identification of new safety information. You can help by reporting any side effects you may get. See the end of section 4 for how to report side effects.

**Read all of this leaflet carefully before you start using this medicine because it contains important information for you.**

- Keep this leaflet. You may need to read it again.
- If you have any further questions, ask your doctor, pharmacist or nurse.
- This medicine has been prescribed for you only. Do not pass it on to others. It may harm them, even if their signs of illness are the same as yours.
- If you get any side effects, talk to your doctor, pharmacist or nurse. This includes any possible side effects not listed in this leaflet. See section 4.

**What is in this leaflet**

1. What Hemlibra is and what it is used for
2. What you need to know before you use Hemlibra
3. How to use Hemlibra
4. Possible side effects
5. How to store Hemlibra
6. Contents of the pack and other information
7. Instructions for use

**1. What Hemlibra is and what it is used for**

**What Hemlibra is**

Hemlibra contains the active substance “emicizumab”. This belongs to a group of medicines called “monoclonal antibodies”. Monoclonal antibodies are a type of protein that recognise and bind to a target in the body.

**What Hemlibra is used for**

Hemlibra is a medicine used for treating patients of all ages with haemophilia A who have developed factor VIII inhibitors

The medicine prevents bleeding or reduces bleeding episodes in people with this condition. Haemophilia A is an inherited condition caused by a lack of factor VIII, an essential substance required for blood to clot and stop any bleeding.

**How Hemlibra works**

Patients with haemophilia A are normally treated with infusion (drip) of replacement factor VIII, but some patients develop factor VIII inhibitors (antibodies against factor VIII) which stop the replacement factor VIII from working. However, because its structure is different from factor VIII, Hemlibra is not affected by factor VIII inhibitors.

## 2. What you need to know before you use Hemlibra

### Do not use Hemlibra:

- if you are allergic to emicizumab or any of the other ingredients of this medicine (listed in section 6). If you are not sure, talk to your doctor, pharmacist or nurse before using Hemlibra.

### Warnings and precautions

**Before you start using Hemlibra, it is very important to talk to your doctor about using “bypassing agents” (medicines that help blood clot but which work in a different way from factor VIII). This is because treatment with bypassing agents may need to change while receiving Hemlibra.** Examples of bypassing agents include activated prothrombin complex concentrate (aPCC) and recombinant FVIIa (rFVIIa). Serious and potentially life-threatening side effects can occur when aPCC is used in patients who are also receiving Hemlibra: **Potentially serious side effects of using aPCC while receiving Hemlibra**

- **Destruction of red blood cells (thrombotic microangiopathy)**
  - This is a serious and potentially life-threatening condition.
  - When people have this condition, the lining of the blood vessels can be damaged and blood clots may develop in small blood vessels. In some cases, this can cause damage to the kidneys and other organs.
  - Be cautious if you are at high risk for this condition (have had this condition in the past, or a member of your family have suffered from it), or if you are taking medicines that can increase the risk of developing this condition, such as ciclosporin, quinine or tacrolimus.
  - It is important to know the symptoms of thrombotic microangiopathy, in case you develop the condition (see section 4, “Possible side effects” for a list of symptoms).

**Stop using Hemlibra and aPCC, and talk to a doctor immediately** if you or your caregiver notices any symptoms of thrombotic microangiopathy.

- **Blood clots (thromboembolism)**
  - In rare cases, a blood clot can form inside blood vessels and block them, which may be life-threatening.
  - It is important to know the symptoms of such internal blood clots, in case they develop (see section 4, “Possible side effects” for a list of symptoms).

**Stop using Hemlibra and aPCC, and talk to a doctor immediately** if you or your caregiver notices any symptoms of blood clots in blood vessels.

### Children below the age of 1 year

In children less than one year of age, the blood system is still developing. If your child is less than one year old, your doctor may prescribe Hemlibra only after carefully weighing the expected benefits and risks of using this product.

### Other medicines and Hemlibra

Tell your doctor or pharmacist if you are using, have recently used or might use any other medicines.

- Using a bypassing agent while receiving Hemlibra
  - **Before you start using Hemlibra, talk to your doctor and carefully follow their instructions on when to use a bypassing agent and the dose and schedule you should use.** Hemlibra increases the ability of your blood to clot. Therefore, the dose of bypassing agent required may be lower than the dose you used before starting Hemlibra.

- Use aPCC **only** if no other treatment can be used. If aPCC is required, talk to your doctor in case you feel you need a total of more than 50 units/kg of aPCC. For more information on using aPCC while receiving Hemlibra, see in section 2: "Potentially serious side effects of using aPCC while receiving Hemlibra".
- Despite limited experience with concomitant administration of anti-fibrinolytics with aPCC or rFVIIa in patients treated with Hemlibra, you should know that there may be a possibility of thrombotic events using anti-fibrinolytics administered intravenously in combination with aPCC or rFVIIa.

### **Laboratory tests**

Tell your doctor if you are using Hemlibra before you have laboratory tests to measure how well your blood is clotting. This is because Hemlibra in the blood may interfere with some laboratory tests, leading to inaccurate results.

### **Pregnancy and breast-feeding**

- You should use an effective method of birth control (contraception) during treatment with Hemlibra and for 6 months after your last injection of Hemlibra.
- If you are pregnant or breast-feeding, think you may be pregnant or are planning to have a baby, ask your doctor or pharmacist for advice before using this medicine. Your doctor will consider the benefit of you taking Hemlibra against the risk to your baby.

### **Driving and using machines**

This medicine is not likely to affect your ability to drive or use machines.

## **3. How to use Hemlibra**

Hemlibra is provided in single-use vials as ready to use solution which does not need to be diluted. A doctor qualified to care for patients with haemophilia will start you on treatment with Hemlibra. Always use this medicine exactly as your doctor has told you. Check with your healthcare provider if you are not sure.

### **Keeping a record**

Each time you use Hemlibra, record the name and batch number of the medicine.

### **How much Hemlibra to use**

The dose of Hemlibra depends on your weight and your doctor will calculate the amount (in mg) and corresponding amount of Hemlibra solution (in mL) to be injected:

- Weeks 1 to 4: The dose is 3 milligrams for every 1 kilogram you weigh, injected once a week.
- Week 5 and onwards: The dose is 1.5 milligrams for every 1 kilogram you weigh, injected once a week.

Different Hemlibra concentrations (30 mg/mL and 150 mg/mL) **should not** be combined when making up the total volume to be injected.

The amount of Hemlibra solution given in each injection must not be more than 2 mL.

## **How Hemlibra is given**

**If you inject Hemlibra yourself or if your caregiver injects it, you or your caregiver must carefully read and follow the instructions in section 7, "Instructions for use".**

- Hemlibra is given by injection under the skin (subcutaneously).
- Your doctor or nurse will show you how to inject Hemlibra.
- Once you have been trained, you should be able to inject this medicine at home, by yourself or with the help of a caregiver.
- To correctly insert the needle under the skin, pinch a fold of loose skin at the clean injection site with your free hand. Pinching the skin is important to ensure that you inject under the skin (into fatty tissue) but not any deeper (into muscle). Injecting into a muscle could cause discomfort.
- Prepare and give the injection in clean and germ-free conditions using aseptic technique. Your doctor or nurse will give more information about this.

## **Where to inject Hemlibra**

- Your doctor will show you which areas of the body are suitable for injecting Hemlibra.
- The recommended places to give an injection are: the front of the waist (lower abdomen), upper outer arms, or the front of the thighs. Use only recommended places for injection.
- For each injection, use a different area of the body to the one you used last time.
- Do not give injections where the skin is red, bruised, tender, hard, or areas where there are moles or scars.
- When using Hemlibra, any other medicine injected under the skin should be given in a different area.

## **Using syringes and needles**

- A syringe, a transfer needle, and an injection needle are needed to draw up the Hemlibra solution from the vial into the syringe and to inject it under the skin.
- Syringes, transfer needles, and injection needles are not provided in this pack. For more information, see in section 6 "What is needed for Hemlibra administration and is not contained in this pack".
- Make sure that you use a new injection needle for each injection and dispose of it after a single use.
- A 1 mL syringe should be used for an injection up to 1 mL of Hemlibra solution.
- A 2 to 3 mL syringe should be used for an injection greater than 1 mL and up to 2 mL of Hemlibra solution.

## **Use in children and adolescents**

Hemlibra can be used in adolescents and children of all ages.

- A child can self-inject the medicine provided the child's healthcare provider and the parent or caregiver agree. Self-injection for children below the age of 7 years is not recommended.

## **If you use more Hemlibra than you should**

If you use more Hemlibra than you are supposed to, tell your doctor immediately. This is because you may be at risk of developing side effects such as blood clots. Always use Hemlibra exactly as your doctor has told you, and check with your doctor, pharmacist or nurse if you are not sure.

## **If you forget to use Hemlibra**

- If you forget your scheduled weekly injection, inject the forgotten dose as soon as possible before the day of the next scheduled dose. Then, continue to inject the medicine once a week as scheduled. Do not inject a double dose to make up for a forgotten dose.
- If you are not sure what to do, ask your doctor, pharmacist or nurse.

#### **If you stop using Hemlibra**

Do not stop using Hemlibra without talking to your doctor. If you stop using Hemlibra, you may no longer be protected against bleeding.

If you have any further questions on the use of this medicine, ask your doctor, pharmacist or nurse.

#### **4. Possible side effects**

Like all medicines, this medicine can cause side effects, although not everybody gets them.

#### **Serious side effects of using aPCC while receiving Hemlibra**

**Stop using Hemlibra and aPCC and talk to a doctor immediately** if you or your caregiver notices any of the following side effects:

- **Destruction of red blood cells (thrombotic microangiopathy):**
  - confusion, weakness, swelling of arms and legs, yellowing of skin and eyes, vague belly (abdominal) or back pain, feeling sick (nausea), being sick (vomiting) or urinating less – these symptoms may be signs of thrombotic microangiopathy.
- **Blood clots (thromboembolism):**
  - swelling, warmth, pain or redness – these symptoms may be signs of a blood clot in a vein near the surface of the skin.
  - headache, numbness in your face, eye pain or swelling or problems with your vision – these symptoms may be signs of a blood clot in a vein behind your eye.
  - blackening of the skin – this symptom may be a sign of severe damage to the skin tissue.

#### **Other side effects when using Hemlibra**

**Very common:** may affect more than 1 in 10 people

- a reaction in the area where the injection is given (redness, itching, pain)
- headache

**Common:** may affect up to 1 in 10 people

- fever
- joint pain
- muscle aches
- diarrhoea
- destruction of red blood cells (thrombotic microangiopathy)

**Uncommon:** may affect up to 1 in 100 people

- blood clot in a vein behind your eye
- severe damage of the skin tissue (skin necrosis)
- blood clot in a vein near the surface of the skin (superficial thrombophlebitis)

#### **Reporting of side effects**

If you get any side effects, talk to your doctor, pharmacist or nurse. This includes any possible side effects not listed in this leaflet. You can also report side effects directly via [the national reporting system listed in Appendix V](#). By reporting side effects, you can help provide more information on the safety of this medicine.

## 5. How to store Hemlibra

Keep this medicine out of the sight and reach of children.

Do not use this medicine after the expiry date which is stated on the carton and the vial label after "EXP". The expiry date refers to the last day of that month.

Store in a refrigerator (2°C to 8°C). Do not freeze.

Store in the original pack in order to protect from light.

Once removed from the refrigerator, unopened vials may be kept at room temperature (below 30°C) for up to 7 days. After storage at room temperature, unopened vials may be returned back to the refrigerator. The total time the medicine is stored at room temperature should not be more than 7 days.

Discard vials that have been kept at room temperature for more than 7 days or exposed to temperatures above 30°C.

Once transferred from the vial to the syringe, use Hemlibra straight away. Do not refrigerate the solution in the syringe.

Before using the medicine, check the solution for particles or discoloration. The solution should be colourless to slightly yellow. Do not use this medicine if it is cloudy, discoloured, or contains visible particles.

Throw away any unused solution appropriately. Do not throw away any medicines via wastewater or household waste. Ask your pharmacist how to throw away medicines you no longer use. These measures will help protect the environment.

## 6. Contents of the pack and other information

### What Hemlibra contains

- The active substance is emicizumab. Each vial of Hemlibra contains 30 mg (1 mL at a concentration of 30 mg/mL) of emicizumab.
- The other ingredients are L-arginine, L-histidine, L-aspartic acid, poloxamer 188 and water for injections.

### What Hemlibra looks like and contents of the pack

Hemlibra is a solution for injection. It is a colourless to slightly yellow liquid.

Each pack of Hemlibra contains 1 glass vial.

What is needed for Hemlibra administration and is not contained in this pack

A syringe, a transfer needle, and an injection needle are needed to withdraw the Hemlibra solution from the vial to a syringe and inject it under the skin (see section 7, "Instructions for use").

### Syringes

- **1 mL syringe:** Transparent polypropylene or polycarbonate syringe with Luer-lock tip, graduation 0.01 mL or
- **2 to 3 mL syringe:** Transparent polypropylene or polycarbonate syringe with Luer-lock tip, graduation 0.1 mL.

## Needles

- **Transfer needle:** Stainless steel with Luer-lock connection, gauge 18 G, length 35mm (1½"), preferably semi-blunted tip, **and**
- **Injection needle:** Stainless steel with Luer-lock connection, gauge 26 G, length preferably 9 mm (3/8") or maximally 13mm (½"), preferably including needle safety feature.

## Marketing Authorisation Holder

Roche Registration Limited  
6 Falcon Way  
Shire Park  
Welwyn Garden City  
AL7 1TW  
United Kingdom

## Manufacturers

Roche Pharma AG  
Emil-Barell-Strasse 1  
D-79639 Grenzach-Wyhlen  
Germany

Roche Austria GmbH  
Engelhorngasse 3  
A-1211 Wien  
Austria

For any information about this medicine, please contact the local representative of the Marketing Authorisation Holder:

**België/Belgique/Belgien**  
N.V. Roche S.A.  
Tél/Tel: +32 (0) 2 525 82 11

**България**  
Рош България ЕООД  
Тел: +359 2 818 44 44

**Česká republika**  
Roche s. r. o.  
Tel: +420 - 2 20382111

**Danmark**  
Roche a/s  
Tlf: +45 - 36 39 99 99

**Deutschland**  
Roche Pharma AG  
Tel: +49 (0) 7624 140

**Eesti**  
Roche Eesti OÜ  
Tel: + 372 - 6 177 380

**Lietuva**  
UAB "Roche Lietuva"  
Tel: +370 5 2546799

**Luxembourg/Luxemburg**  
(Voir/siehe Belgique/Belgien)

**Magyarország**  
Roche (Magyarország) Kft.  
Tel: +36 - 23 446 800

**Malta**  
(See United Kingdom)

**Nederland**  
Roche Nederland B.V.  
Tel: +31 (0) 348 438050

**Norge**  
Roche Norge AS  
Tlf: +47 - 22 78 90 00



**Ελλάδα**

Roche (Hellas) A.E.  
Τηλ: +30 210 61 66 100

**España**

Roche Farma S.A.  
Tel: +34 - 91 324 81 00

**France**

Roche  
Tél: +33 (0) 1 47 61 40 00

**Hrvatska**

Roche d.o.o.  
Tel: +385 1 4722 333

**Ireland**

Roche Products (Ireland) Ltd.  
Tel: +353 (0) 1 469 0700

**Ísland**

Roche a/s  
c/o Icepharma hf  
Sími: +354 540 8000

**Italia**

Roche S.p.A.  
Tel: +39 - 039 2471

**Κύπρος**

Γ.Α.Σταμάτης & Σια Λτδ.  
Τηλ: +357 - 22 76 62 76

**Latvija**

Roche Latvija SIA  
Tel: +371 - 6 7039831

**Österreich**

Roche Austria GmbH  
Tel: +43 (0) 1 27739

**Polska**

Roche Polska Sp.z o.o.  
Tel: +48 - 22 345 18 88

**Portugal**

Roche Farmacêutica Química, Lda  
Tel: +351 - 21 425 70 00

**România**

Roche România S.R.L.  
Tel: +40 21 206 47 01

**Slovenija**

Roche farmacevtska družba d.o.o.  
Tel: +386 - 1 360 26 00

**Slovenská republika**

Roche Slovensko, s.r.o.  
Tel: +421 - 2 52638201

**Suomi/Finland**

Roche Oy  
Puh/Tel: +358 (0) 10 554 500

**Sverige**

Roche AB  
Tel: +46 (0) 8 726 1200

**United Kingdom**

Roche Products Ltd.  
Tel: +44 (0) 1707 366000

**This leaflet was last revised in**

**Other sources of information**

Detailed information on this medicine is available on the European Medicines Agency web site:  
<http://www.ema.europa.eu>

## 7. Instructions for use

Instructions for Use  
Hemlibra  
Injection  
Single-Dose Vial(s)

You must read, understand and follow the Instructions for Use before injecting Hemlibra. Your healthcare provider should show you how to prepare, measure, and inject Hemlibra properly before you use it for the first time. Ask your healthcare provider if you have any questions.

### Important Information:

- **Do not** inject yourself or someone else unless you have been shown how to by your healthcare provider.
- Make sure the name Hemlibra is on the box and vial label.
- Before opening the vial, read the vial label to make sure you have the correct medicine strength(s) to give the dose prescribed for you. You may need to use more than 1 vial to give yourself the correct dose.
- Check the expiry date on the box and vial label. **Do not** use if the expiry date has passed.
- **Only use the vial once.** After you inject your dose, throw away any unused Hemlibra left in the vial. Do not save unused medicine in the vial for later use.
- **Only use the syringes, transfer needles, and injection needles that your healthcare provider prescribes.**
- **Use the syringes, transfer needles and injection needles only once. Throw away any used syringes and needles.**
- If your prescribed dose is more than 2 mL, you will need to have more than one subcutaneous injection of Hemlibra; contact your healthcare provider for the injection instructions.
- You must inject Hemlibra only under the skin.

### Storing Hemlibra vials, needles and syringes:

- Keep the vial in the original box to protect the medicine from light.
- Keep the vials, needles and syringes out of the sight and reach of children. Store the vial in the refrigerator.
- **Do not** freeze.
- **Do not** shake the vial.
- Take the vial out of the refrigerator 15 minutes before use and allow it to reach room temperature (below 30 C) before preparing an injection.
- Once removed from the refrigerator, the unopened vial can be kept at room temperature for up to 7 days. After storage at room temperature unopened vials may be returned to the refrigerator. The total amount of time outside cold storage and at room temperature should not exceed 7 days.

- Discard vials that have been kept at room temperature for more than 7 days or have been in temperatures above 30°C.
- Keep the transfer needle, injection needle and syringe dry.

**Inspecting the medicine and your supplies:**

- Collect all supplies listed below to prepare and give your injection.
- **Check** the expiry date on the box, on the vial label and on the supplies listed below. **Do not use** if the expiry date has passed.
- **Do not use** the vial if:
  - the medicine is cloudy, hazy or coloured.
  - the medicine contains particles.
  - the cap covering the stopper is missing.
- Inspect the supplies for damage. **Do not use** if they appear damaged or if they have been dropped.
- Place the supplies on a clean, well-lit flat work surface.

**INCLUDED IN THE BOX:**

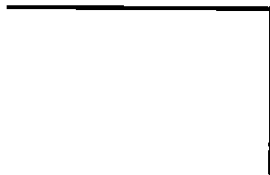

- **Vial containing the medicine**

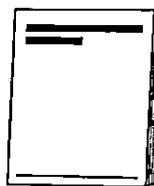

- **Instructions for Use**

NOT INCLUDED IN THE BOX:

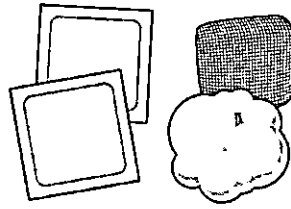

- **Alcohol wipes**

**Note:** If you need to use more than 1 vial to inject your prescribed dose, you must use a new alcohol wipe for each vial.

- **Gauze**
- **Cotton Ball**

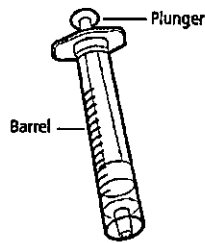

- **Syringe**

**Note:** For injection amount up to 1 mL use a **1 mL syringe**.

For injection amount between 1 mL and 2 mL use a **2 mL or 3 mL syringe**.

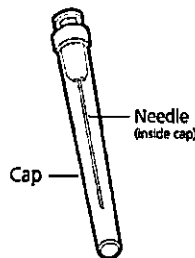

- **18G Transfer Needle**

**Note:** If you need to use more than 1 vial to inject your prescribed dose, you must use a new transfer needle for each vial.

**Do not** use the transfer needle to inject the medicine.

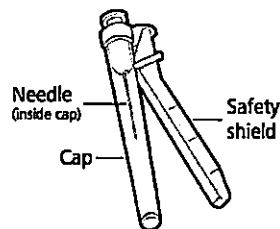

- **26G Injection Needle with safety shield**

**Do not** use the injection needle to withdraw medicine from vial.



- **Sharps disposal container**

**Get ready:**

- Before use, allow the vial(s) to reach room temperature for about 15 minutes on a clean flat surface away from direct sunlight.
- Do not try to warm the vial by any other way.
- Wash your hands well with soap and water.

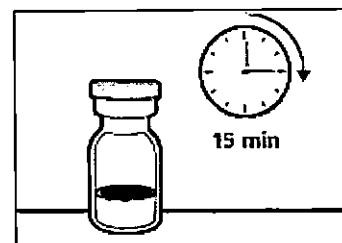

**Figure A**

**Selecting and preparing an injection site:**

- Clean the chosen injection site area using an alcohol wipe.
- Let the skin dry for about 10 seconds. Do not touch, fan or blow on the cleaned area before your injection.

**For injection, you can use your:**

- Thigh (front and middle).
- Stomach area (abdomen), except for 5 cm around the navel (belly button).
- Outer area of the upper arm (only if a caregiver is giving the injection).
- You should use a different injection site for each injection, at least 2.5 cm away from the area you used for your previous injection.
- Do not inject into areas that could be irritated by a belt or waistband. Do not inject into moles, scars, bruises, or areas where the skin is tender, red, hard or the skin is broken.

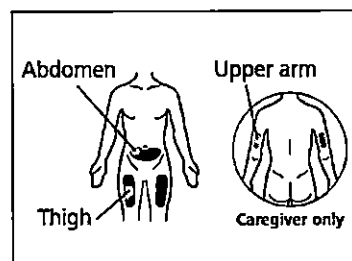

**Figure B**

**Preparing the syringe for injection:**

- Do not touch exposed needles or place them on a surface once the cap has been removed.
- Once the syringe has been filled with the medicine, the injection must be given immediately.
- Once the injection needle cap has been removed, the medicine in the syringe must be injected under the skin within 5 minutes. Do not use the syringe if the needle touches any surface
- **Throw away any used vial(s), needles, vial or injection needle caps and used syringes in a sharps or puncture-proof container.**

**Important information after the injection:**

- Do not rub the injection site after injection.
- If you see drops of blood at the injection site, you can press a sterile cotton ball or gauze over the injection site for at least 10 seconds, until bleeding has stopped.
- If you have bruising (small area of bleeding under the skin), an ice pack can also be pressed gently on the site. If bleeding does not stop, please contact your healthcare provider.

**Disposing of the medicine and supplies:**

**Important: Always keep the sharps disposal container out of reach of children.**

- Put your used needles and syringes in a sharps disposal container straight away after use. Do not throw away any loose needles and syringes in your household waste.
- If you do not have a sharps disposal container, you may use a household container that is:
  - made of heavy-duty plastic.
  - can be closed with a tight-fitting, puncture resistant lid, without sharps being able to come out.
  - upright and stable during use.
  - leak-resistant.
  - properly labelled to warn of hazardous waste inside the container.
- When your sharps disposal container is almost full, you will need to follow your local guidelines for the right way to dispose of your sharps disposal container.
- Do not throw away any used sharps disposal container in your household waste unless your local guidelines permit this. Do not recycle your used sharps disposal container.

**Step 1. Remove vial cap and clean top**

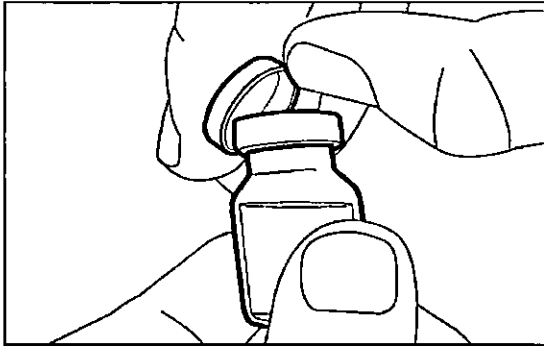

- Take the cap off the vial(s).

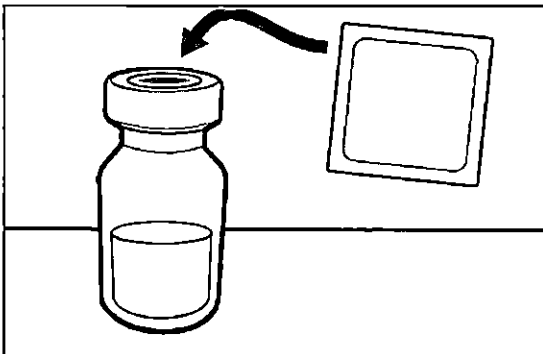

- Clean the top of the vial(s) stopper with an alcohol wipe.
- Throw away the vial cap(s) into the sharps disposal container.

**Step 2. Attach transfer needle to syringe**

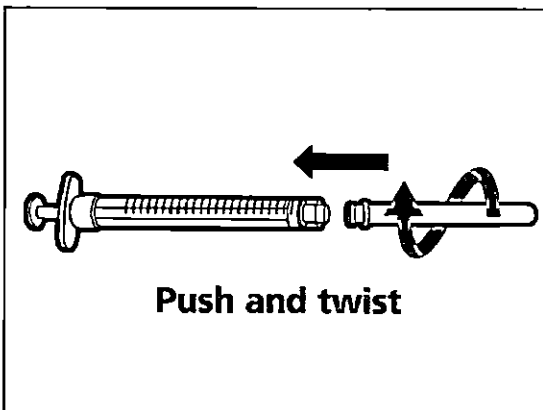

- Push and twist the transfer needle clockwise on to the syringe until it is fully attached.

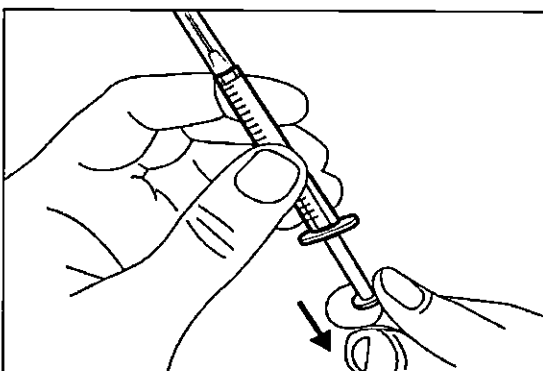

- Slowly pull back on the plunger and draw air into the syringe that is the same amount as your prescribed dose.

### Step 3. Uncap transfer needle

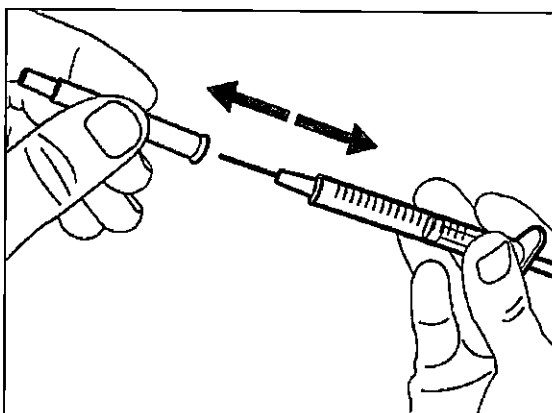

- Hold the syringe by the barrel with the transfer needle pointing up.
- Carefully pull the transfer needle cap straight off and away from your body. **Do not throw the cap away. Place the transfer needle cap down on a clean flat surface.** You will need to recap the transfer needle after transferring the medicine.
- **Do not touch** the needle tip or place it on a surface after the needle cap has been removed.

### Step 4. Inject air into vial

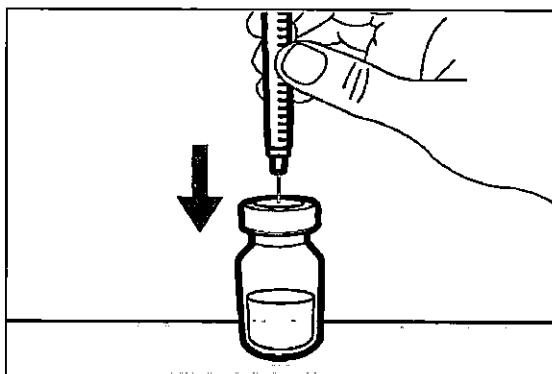

- Keep the vial on the flat working surface and insert the transfer needle and syringe straight down into the centre of the vial stopper.

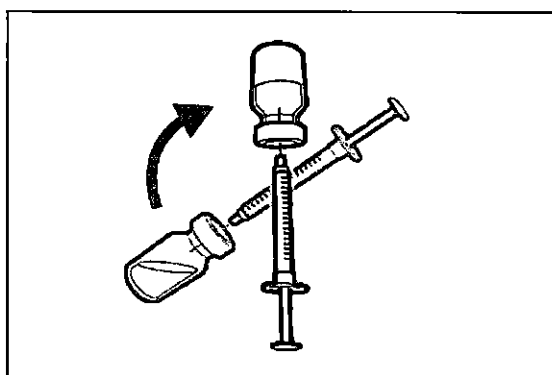

- Keep the needle in the vial and turn the vial upside down.

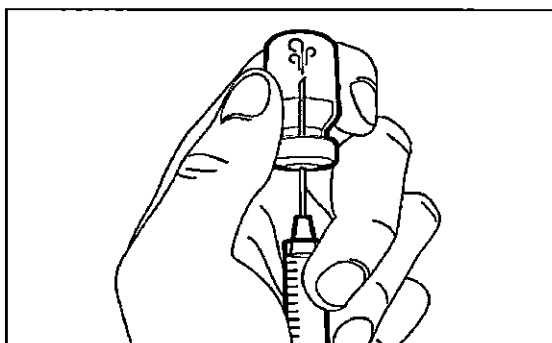

- With the needle pointing upwards, push on the plunger to inject the air from the syringe **above the medicine.**
- Keep your finger pressed down on the syringe plunger.
- **Do not** inject air into the medicine as this could create air bubbles in the medicine.



**Step 5. Transfer medicine to syringe**

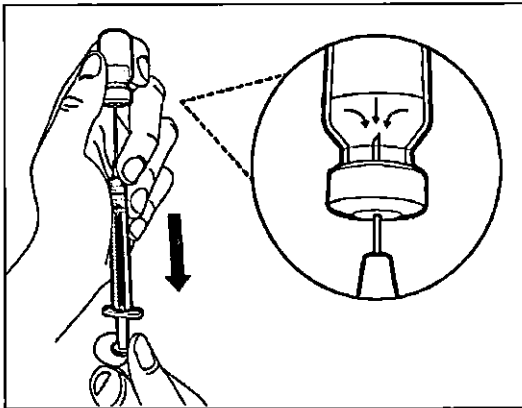

- Slide the tip of the needle down so that it is **within the medicine**.
- Slowly pull back the plunger to fill the syringe with more than the amount of medicine needed for your prescribed dose.
- Be careful not to pull the plunger out of the syringe.

**Important:** If your prescribed dose is more than the amount of medicine in the vial, **withdraw all of the medicine** and go to the “**Combining Vials**” section now.

### Step 6. Remove air bubbles

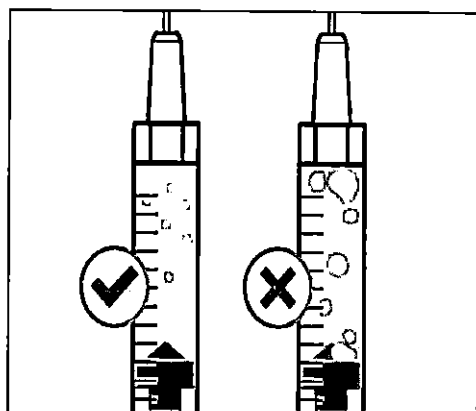
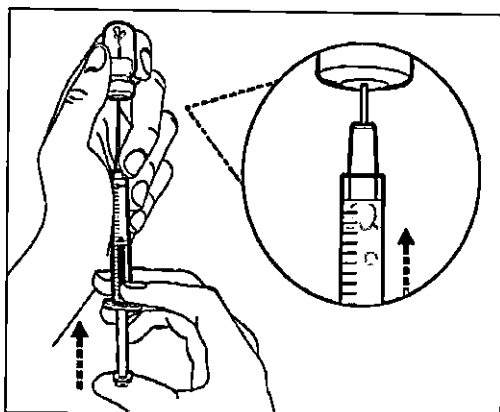

- Keep the needle in the vial and check the syringe for larger air bubbles. Large air bubble can reduce the dose you receive.
- **Remove the larger air bubbles** by gently **tapping** the syringe barrel with your fingers until the air bubbles rise to the top of the syringe. Move the tip of the needle **above the medicine** and slowly push the plunger up to push the air bubbles out of the syringe.
- If the amount of medicine in the syringe is now at or below your prescribed dose, move the tip of the needle to **within the medicine** and slowly **pull back** the plunger until you have **more** than the amount of medicine needed for your **prescribed dose**.
- Be careful not to pull the plunger out of the syringe.
- Repeat the steps above until you have removed the larger air bubbles.

**Note:** Ensure you have enough medicine in the syringe to complete your dose before moving onto the next step. If you cannot remove all medicine, turn the vial upright to reach the remaining amount

 **Do not** use the transfer needle to inject medicine as this may cause pain and bleeding

### Step 7. Recap transfer needle

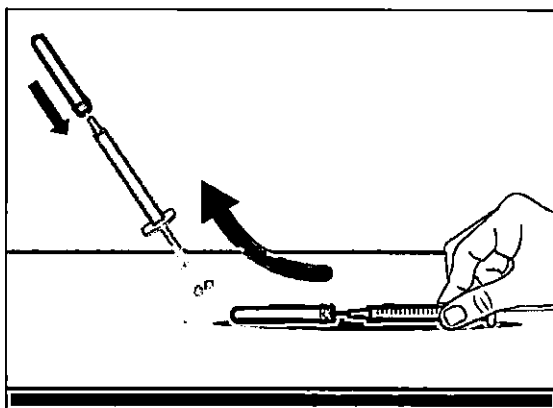

- Remove the syringe and transfer needle from the vial.
- **Using one hand, slide** the transfer needle into the cap and **scoop upwards** to cover the needle.
- Once the needle is covered, push the transfer needle cap towards the syringe to fully attach it with **one hand** to prevent accidentally injuring yourself with the needle.

**Step 8. Clean injection site**

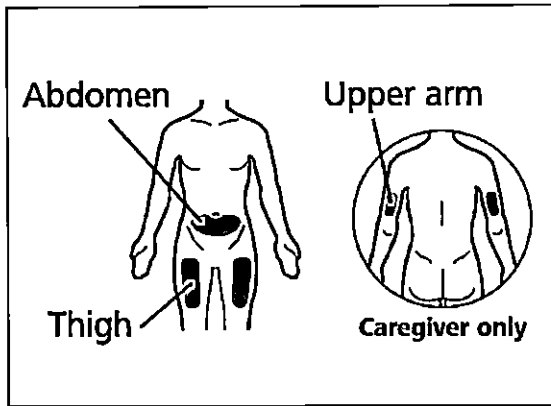

- Select and **clean** your injection site with an alcohol wipe.

**Step 9. Remove transfer needle**

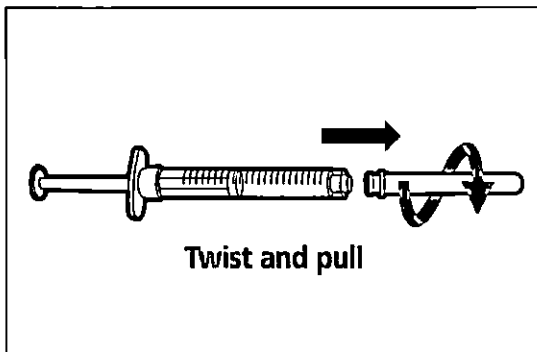

- Remove the transfer needle from the syringe by twisting anticlockwise and gently pulling.
- Throw away the used transfer needle into a sharps disposal container.

**Step 10. Attach injection needle to syringe**

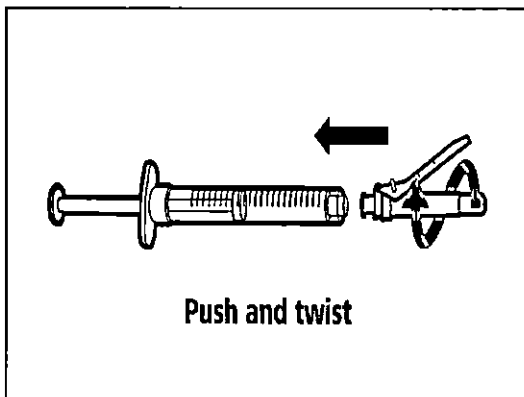

- Push and twist the injection needle clockwise onto the syringe until it is fully attached.

**Step 11. Move safety shield**

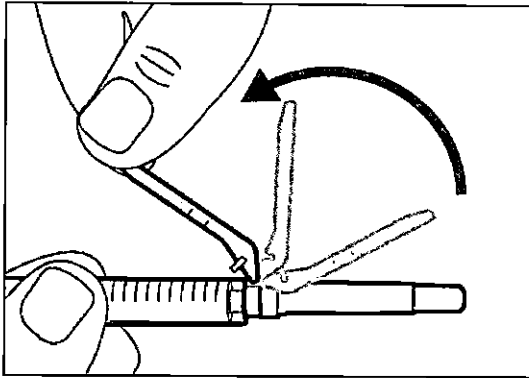

- Move the safety shield away from the needle and **towards** the syringe barrel.

**Step 12. Uncap injection needle**

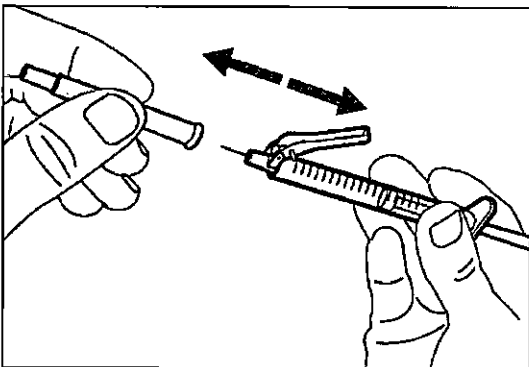

- Carefully pull the injection needle cap away from the syringe.
- Throw away the cap into a sharps disposal container.
- **Do not touch** the needle tip or allow it to touch any surface.
- After the injection needle cap has been removed, the medicine in the syringe must be injected within 5 minutes.

### Step 13. Adjust plunger to prescribed dose

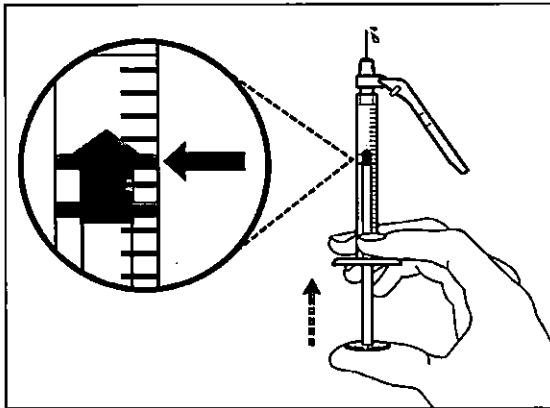

- Slowly push the plunger to your prescribed dose.
- Ensure the top rim of the plunger is in line with the mark on the syringe for your prescribed dose.

### Step 14. Subcutaneous (under the skin) injection

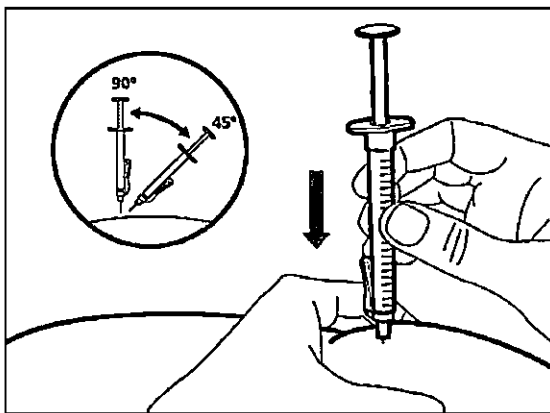

- Pinch the selected injection site and fully insert the needle at a  $45^\circ$  to  $90^\circ$  angle with a quick, firm action. **Do not** hold or push on the plunger while inserting the needle.
- Hold the position of the syringe and let go of the pinched injection site.

### Step 15. Inject the medicine

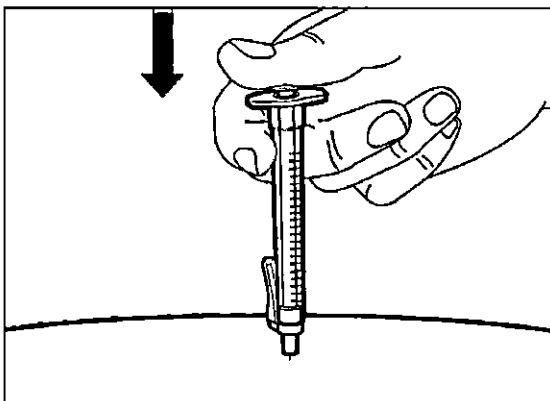

- Slowly inject all of the medicine by gently pushing the plunger all the way down.
- Remove the needle and syringe from the injection site at the same angle as inserted.

**Step 16. Cover needle with safety shield**

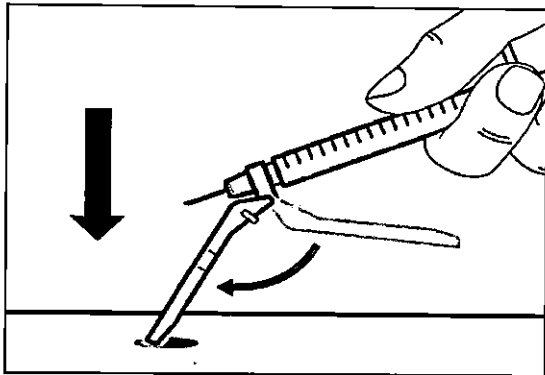

- Move the safety shield forward 90°, away from the syringe barrel.
- Holding the syringe with one hand, **press the safety shield down** against a flat surface with a firm, quick motion until you hear a “click”.

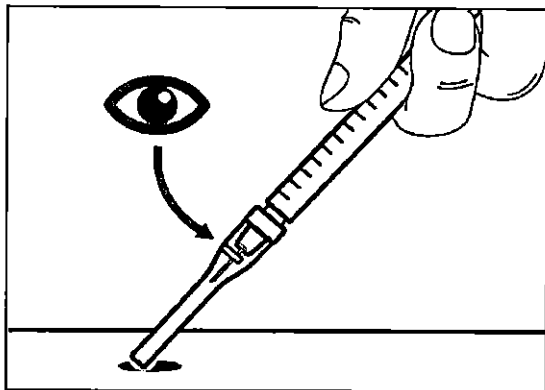

- If you do not hear a click, look to see that the needle is fully covered by the safety shield.
- Keep your fingers behind the safety shield and away from the needle at all times.
- **Do not** detach injection needle

**Step 17. Throw away the syringe and needle.**

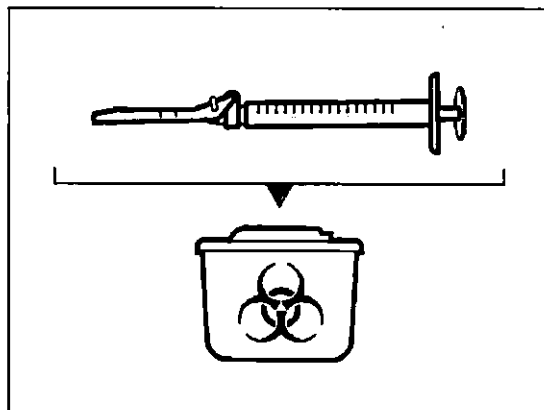

- Put **your** used needles and syringes in a sharps disposal container right away after use. For further information refer to the section “Disposing of the medicine and supplies”.
- **Do not** try to remove the used injection needle from the used syringe.
- **Do not** recap the injection needle with the cap.
- **Important:** Always keep the sharps disposal container out of reach of children.

## Combining Vials

If you need to use more than 1 vial to get to your total prescribed dose, follow these steps after you have drawn up the medicine from the first vial:

### Step A. Recap transfer needle

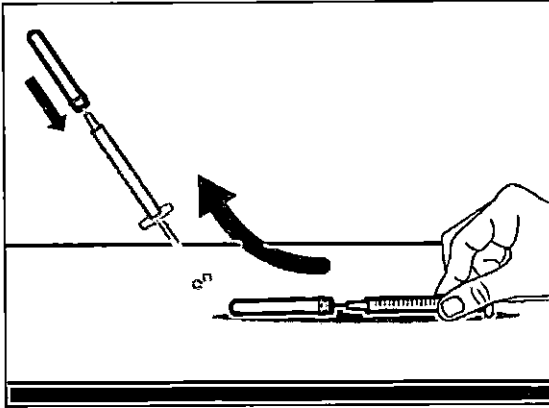

- Remove the syringe and transfer needle from the first vial.
- **Using one hand**, slide the transfer needle into the cap and **scoop upwards** to cover the needle.
- Once the needle is covered, push the transfer needle cap toward the syringe to fully attach it with **one hand** to prevent accidentally injuring yourself with the needle.

### Step B. Remove transfer needle

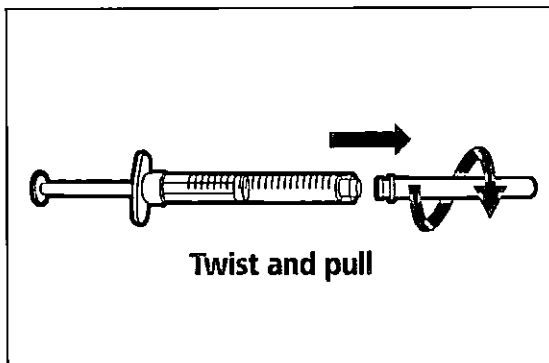

- Remove the transfer needle from the syringe by twisting anticlockwise and gently pulling.
- Throw away the used transfer needle into a sharps disposal container.

### Step C. Attach a new transfer needle to syringe

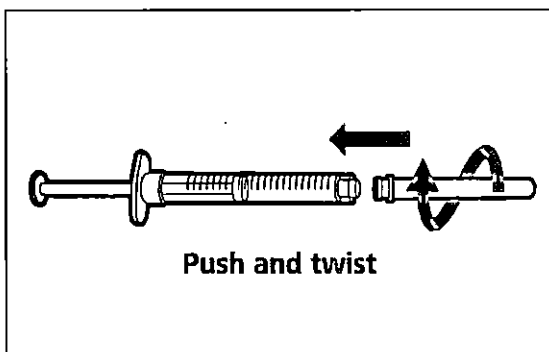

**Note: You must use a new transfer needle each time you withdraw medicine from a new vial.**

- Push and twist a **new** transfer needle clockwise on to the syringe until it is fully attached.
- Slowly pull back the plunger and draw some air into the syringe.

**Step D. Uncap transfer needle**

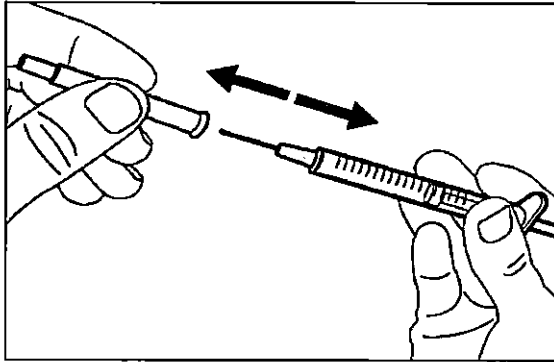

- Hold the syringe by the barrel with the transfer needle cap pointing up.
- Carefully pull the transfer needle cap straight off and away from your body. Do not throw the cap away. You will need to recap the transfer needle after drawing up the medicine.
- **Do not touch** the needle tip.

**Step E. Inject air into vial**

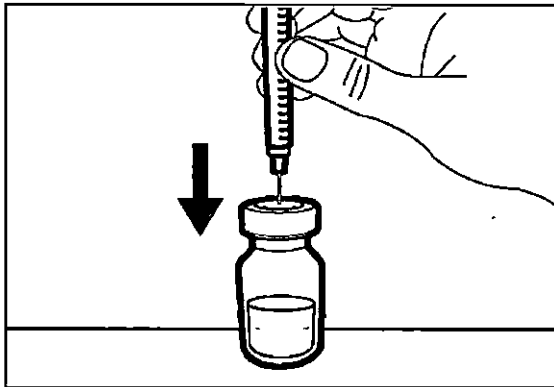

- With the new vial on the flat working surface, insert the new transfer needle and syringe, straight down into the **center** of the vial stopper.

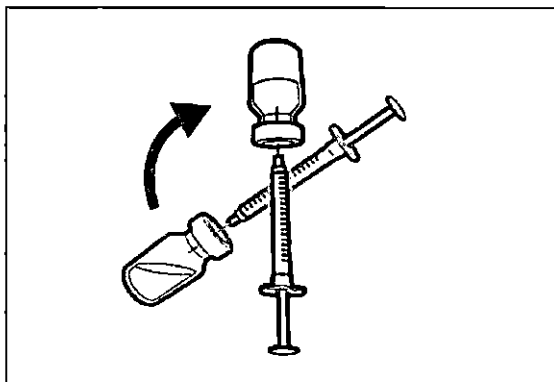

- Keep the transfer needle in the vial and turn the vial upside down.

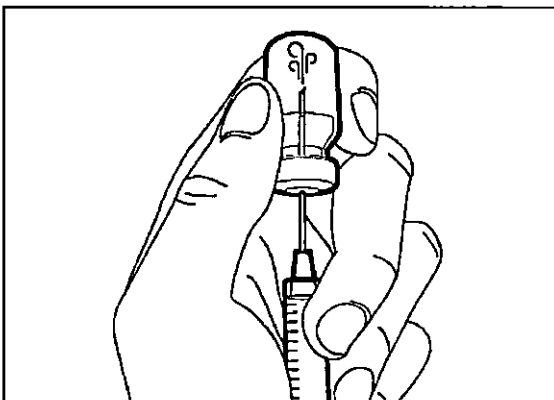

- With the needle pointing upwards, inject the air from the syringe **above the medicine**.
- Keep your finger pressed down on the syringe plunger.
- **Do not** inject air into the medicine as this could create air bubbles in the medicine.



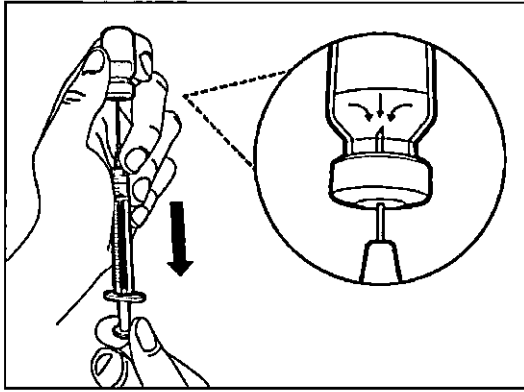

- Slide the tip of the needle down so that it is **within the medicine**.
- Slowly pull back the plunger to fill the syringe barrel more than the amount of medicine needed for your prescribed dose.
- Be careful not to pull the plunger out of the syringe.

**Note:** Ensure you have enough medicine in the syringe to complete your dose before moving onto the next steps. If you cannot remove all medicine, turn the vial upright to reach the remaining amount

**!** Do not use the transfer needle to inject medicine as this may cause harm such as pain and bleeding.

**Repeat steps A to F with each additional vial until you have more than your prescribed dose. Once completed, keep the transfer needle inserted in the vial and return to Step 6. Continue with the remaining steps.**

## **Package leaflet: Information for the user**

### **Hemlibra 150 mg/mL solution for injection emicizumab**

▼ This medicine is subject to additional monitoring. This will allow quick identification of new safety information. You can help by reporting any side effects you may get. See the end of section 4 for how to report side effects.

**Read all of this leaflet carefully before you start using this medicine because it contains important information for you.**

- Keep this leaflet. You may need to read it again.
- If you have any further questions, ask your doctor, pharmacist or nurse.
- This medicine has been prescribed for you only. Do not pass it on to others. It may harm them, even if their signs of illness are the same as yours.
- If you get any side effects, talk to your doctor, pharmacist or nurse. This includes any possible side effects not listed in this leaflet. See section 4.

#### **What is in this leaflet**

1. What Hemlibra is and what it is used for
2. What you need to know before you use Hemlibra
3. How to use Hemlibra
4. Possible side effects
5. How to store Hemlibra
6. Contents of the pack and other information
7. Instructions for use

#### **1. What Hemlibra is and what it is used for**

##### **What Hemlibra is**

Hemlibra contains the active substance “emicizumab”. This belongs to a group of medicines called “monoclonal antibodies”. Monoclonal antibodies are a type of protein that recognise and bind to a target in the body.

##### **What Hemlibra is used for**

Hemlibra is a medicine used for treating patients of all ages with haemophilia A who have developed factor VIII inhibitors

The medicine prevents bleeding or reduces bleeding episodes in people with this condition. Haemophilia A is an inherited condition caused by a lack of factor VIII, an essential substance required for blood to clot and stop any bleeding.

##### **How Hemlibra works**

Patients with haemophilia A are normally treated with infusion (drip) of replacement factor VIII, but some patients develop factor VIII inhibitors (antibodies against factor VIII) which stop the replacement factor VIII from working. However, because its structure is different from factor VIII, Hemlibra is not affected by factor VIII inhibitors.

## 2. What you need to know before you use Hemlibra

### Do not use Hemlibra:

- if you are allergic to emicizumab or any of the other ingredients of this medicine (listed in section 6). If you are not sure, talk to your doctor, pharmacist or nurse before using Hemlibra.

### Warnings and precautions

**Before you start using Hemlibra, it is very important to talk to your doctor about using “bypassing agents” (medicines that help blood clot but which work in a different way from factor VIII). This is because treatment with bypassing agents may need to change while receiving Hemlibra.** Examples of bypassing agents include activated prothrombin complex concentrate (aPCC) and recombinant FVIIa (rFVIIa). Serious and potentially life-threatening side effects can occur when aPCC is used in patients who are also receiving Hemlibra: **Potentially serious side effects of using aPCC while receiving Hemlibra**

- **Destruction of red blood cells (thrombotic microangiopathy)**
  - This is a serious and potentially life-threatening condition.
  - When people have this condition, the lining of the blood vessels can be damaged and blood clots may develop in small blood vessels. In some cases, this can cause damage to the kidneys and other organs.
  - Be cautious if you are at high risk for this condition (have had this condition in the past, or a member of your family have suffered from it), or if you are taking medicines that can increase the risk of developing this condition, such as ciclosporin, quinine or tacrolimus.
  - It is important to know the symptoms of thrombotic microangiopathy, in case you develop the condition (see section 4, “Possible side effects” for a list of symptoms).

**Stop using Hemlibra and aPCC, and talk to a doctor immediately** if you or your caregiver notices any symptoms of thrombotic microangiopathy.

- **Blood clots (thromboembolism)**
  - In rare cases, a blood clot can form inside blood vessels and block them, which may be life-threatening.
  - It is important to know the symptoms of such internal blood clots, in case they develop (see section 4, “Possible side effects” for a list of symptoms).

**Stop using Hemlibra and aPCC, and talk to a doctor immediately** if you or your caregiver notices any symptoms of blood clots in blood vessels.

### Children below the age of 1 year

In children less than one year of age, the blood system is still developing. If your child is less than one year old, your doctor may prescribe Hemlibra only after carefully weighing the expected benefits and risks of using this product.

### Other medicines and Hemlibra

Tell your doctor or pharmacist if you are using, have recently used or might use any other medicines.

- Using a bypassing agent while receiving Hemlibra
  - **Before you start using Hemlibra, talk to your doctor and carefully follow their instructions on when to use a bypassing agent and the dose and schedule you should use.** Hemlibra increases the ability of your blood to clot. Therefore, the dose of bypassing agent required may be lower than the dose you used before starting Hemlibra.

- Use aPCC **only** if no other treatment can be used. If aPCC is required, talk to your doctor in case you feel you need a total of more than 50 units/kg of aPCC. For more information on using aPCC while receiving Hemlibra, see in section 2: “Potentially serious side effects of using aPCC while receiving Hemlibra”.
- Despite limited experience with concomitant administration of anti-fibrinolytics with aPCC or rFVIIa in patients treated with Hemlibra, you should know that there may be a possibility of thrombotic events using anti-fibrinolytics administered intravenously in combination with aPCC or rFVIIa.

### **Laboratory tests**

Tell your doctor if you are using Hemlibra before you have laboratory tests to measure how well your blood is clotting. This is because Hemlibra in the blood may interfere with some laboratory tests, leading to inaccurate results.

### **Pregnancy and breast-feeding**

- You should use an effective method of birth control (contraception) during treatment with Hemlibra and for 6 months after your last injection of Hemlibra.
- If you are pregnant or breast-feeding, think you may be pregnant or are planning to have a baby, ask your doctor or pharmacist for advice before using this medicine. Your doctor will consider the benefit of you taking Hemlibra against the risk to your baby.

### **Driving and using machines**

This medicine is not likely to affect your ability to drive or use machines.

## **3. How to use Hemlibra**

Hemlibra is provided in single-use vials as ready to use solution which does not need to be diluted. A doctor qualified to care for patients with haemophilia will start you on treatment with Hemlibra. Always use this medicine exactly as your doctor has told you. Check with your healthcare provider if you are not sure.

### **Keeping a record**

Each time you use Hemlibra, record the name and batch number of the medicine.

### **How much Hemlibra to use**

The dose of Hemlibra depends on your weight and your doctor will calculate the amount (in mg) and corresponding amount of Hemlibra solution (in mL) to be injected:

- Weeks 1 to 4: The dose is 3 milligrams for every 1 kilogram you weigh, injected once a week.
- Week 5 and onwards: The dose is 1.5 milligrams for every 1 kilogram you weigh, injected once a week.

Different Hemlibra concentrations (30 mg/mL and 150 mg/mL) **should not** be combined when making up the total volume to be injected.

The amount of Hemlibra solution given in each injection must not be more than 2 mL

## **How Hemlibra is given**

**If you inject Hemlibra yourself or if your caregiver injects it, you or your caregiver must carefully read and follow the instructions in section 7, “Instructions for use”.**

- Hemlibra is given by injection under the skin (subcutaneously).
- Your doctor or nurse will show you how to inject Hemlibra.
- Once you have been trained, you should be able to inject this medicine at home, by yourself or with the help of a caregiver.
- To correctly insert the needle under the skin, pinch a fold of loose skin at the clean injection site with your free hand. Pinching the skin is important to ensure that you inject under the skin (into fatty tissue) but not any deeper (into muscle). Injecting into a muscle could cause discomfort.
- Prepare and give the injection in clean and germ-free conditions using aseptic technique. Your doctor or nurse will give more information about this.

## **Where to inject Hemlibra**

- Your doctor will show you which areas of the body are suitable for injecting Hemlibra.
- The recommended places to give an injection are: the front of the waist (lower abdomen), upper outer arms, or the front of the thighs. Use only recommended places for injection.
- For each injection, use a different area of the body to the one you used last time.
- Do not give injections where the skin is red, bruised, tender, hard, or areas where there are moles or scars.
- When using Hemlibra, any other medicine injected under the skin should be given in a different area.

## **Using syringes and needles**

- A syringe, a transfer needle, and an injection needle are needed to draw up the Hemlibra solution from the vial into the syringe and to inject it under the skin.
- Syringes, transfer needles, and injection needles are not provided in this pack. For more information, see in section 6 “What is needed for Hemlibra administration and is not contained in this pack”.
- Make sure that you use a new injection needle for each injection and dispose of it after a single use.
- A 1 mL syringe should be used for an injection up to 1 mL of Hemlibra solution.
- A 2 to 3 mL syringe should be used for an injection greater than 1 mL and up to 2 mL of Hemlibra solution.

## **Use in children and adolescents**

Hemlibra can be used in adolescents and children of all ages.

- A child can self-inject the medicine provided the child’s healthcare provider and the parent or caregiver agree. Self-injection for children below the age of 7 years is not recommended.

## **If you use more Hemlibra than you should**

If you use more Hemlibra than you are supposed to, tell your doctor immediately. This is because you may be at risk of developing side effects such as blood clots. Always use Hemlibra exactly as your doctor has told you, and check with your doctor, pharmacist or nurse if you are not sure.

## **If you forget to use Hemlibra**

- If you forget your scheduled weekly injection, inject the forgotten dose as soon as possible before the day of the next scheduled dose. Then, continue to inject the medicine once a week as scheduled. Do not inject a double dose to make up for a forgotten dose.
- If you are not sure what to do, ask your doctor, pharmacist or nurse.

### **If you stop using Hemlibra**

Do not stop using Hemlibra without talking to your doctor. If you stop using Hemlibra, you may no longer be protected against bleeding.

If you have any further questions on the use of this medicine, ask your doctor, pharmacist or nurse.

### **4. Possible side effects**

Like all medicines, this medicine can cause side effects, although not everybody gets them.

#### **Serious side effects of using aPCC while receiving Hemlibra**

**Stop using Hemlibra and aPCC and talk to a doctor immediately** if you or your caregiver notices any of the following side effects:

- **Destruction of red blood cells (thrombotic microangiopathy):**
  - confusion, weakness, swelling of arms and legs, yellowing of skin and eyes, vague belly (abdominal) or back pain, feeling sick (nausea), being sick (vomiting) or urinating less – these symptoms may be signs of thrombotic microangiopathy.
- **Blood clots (thromboembolism):**
  - swelling, warmth, pain or redness – these symptoms may be signs of a blood clot in a vein near the surface of the skin.
  - headache, numbness in your face, eye pain or swelling or problems with your vision – these symptoms may be signs of a blood clot in a vein behind your eye.
  - blackening of the skin – this symptom may be a sign of severe damage to the skin tissue.

#### **Other side effects when using Hemlibra**

**Very common:** may affect more than 1 in 10 people

- a reaction in the area where the injection is given (redness, itching, pain)
- headache

**Common:** may affect up to 1 in 10 people

- fever
- joint pain
- muscle aches
- diarrhoea
- destruction of red blood cells (thrombotic microangiopathy)

**Uncommon:** may affect up to 1 in 100 people

- blood clot in a vein behind your eye
- severe damage of the skin tissue (skin necrosis)
- blood clot in a vein near the surface of the skin (superficial thrombophlebitis)

#### **Reporting of side effects**

If you get any side effects, talk to your doctor, pharmacist or nurse. This includes any possible side effects not listed in this leaflet. You can also report side effects directly via the national reporting system listed in Appendix V. By reporting side effects, you can help provide more information on the safety of this medicine.

## 5. How to store Hemlibra

Keep this medicine out of the sight and reach of children.

Do not use this medicine after the expiry date which is stated on the carton and the vial label after "EXP". The expiry date refers to the last day of that month.

Store in a refrigerator (2°C to 8°C). Do not freeze.

Store in the original pack in order to protect from light.

Once removed from the refrigerator, unopened vials may be kept at room temperature (below 30°C) for up to 7 days. After storage at room temperature, unopened vials may be returned back to the refrigerator. The total time the medicine is stored at room temperature should not be more than 7 days.

Discard vials that have been kept at room temperature for more than 7 days or exposed to temperatures above 30°C.

Once transferred from the vial to the syringe, use Hemlibra straight away. Do not refrigerate the solution in the syringe.

Before using the medicine, check the solution for particles or discoloration. The solution should be colourless to slightly yellow. Do not use this medicine if it is cloudy, discoloured, or contains visible particles.

Throw away any unused solution appropriately. Do not throw away any medicines via wastewater or household waste. Ask your pharmacist how to throw away medicines you no longer use. These measures will help protect the environment.

## 6. Contents of the pack and other information

### What Hemlibra contains

- The active substance is emicizumab. Each vial of Hemlibra contains 60 mg (0.4 mL at a concentration of 150 mg/mL), 105 mg (0.7 mL at a concentration of 150 mg/mL) or 150 mg (1 mL at a concentration of 150 mg/mL) of emicizumab.
- The other ingredients are L-arginine, L-histidine, L-aspartic acid, poloxamer 188 and water for injections.

### What Hemlibra looks like and contents of the pack

Hemlibra is a solution for injection. It is a colourless to slightly yellow liquid.

Each pack of Hemlibra contains 1 glass vial.

What is needed for Hemlibra administration and is not contained in this pack

A syringe, a transfer needle, and an injection needle are needed to withdraw the Hemlibra solution from the vial to a syringe and inject it under the skin (see section 7, "Instructions for use").

### Syringes

- **1 mL syringe:** Transparent polypropylene or polycarbonate syringe with Luer-lock tip, graduation 0.01 mL or
- **2 to 3 mL syringe:** Transparent polypropylene or polycarbonate syringe with Luer-lock tip, graduation 0.1 mL.

## Needles

- **Transfer needle:** Stainless steel with Luer-lock connection, gauge 18 G, length 35mm (1½"), preferably semi-blunted tip, **and**
- **Injection needle:** Stainless steel with Luer-lock connection, gauge 26 G, length preferably 9 mm (3/8") or maximally 13mm (½"), preferably including needle safety feature.

## Marketing Authorisation Holder

Roche Registration Limited  
6 Falcon Way  
Shire Park  
Welwyn Garden City  
AL7 1TW  
United Kingdom

## Manufacturers

Roche Pharma AG  
Emil-Barell-Strasse 1  
D-79639 Grenzach-Wyhlen  
Germany

Roche Austria GmbH  
Engelhorngasse 3  
A-1211 Wien  
Austria

For any information about this medicine, please contact the local representative of the Marketing Authorisation Holder:

### België/Belgique/Belgien

N.V. Roche S.A.  
Tél/Tel: +32 (0) 2 525 82 11

### Lietuva

UAB "Roche Lietuva"  
Tel: +370 5 2546799

### България

Рош България ЕООД  
Тел: +359 2 818 44 44

### Luxembourg/Luxemburg

(Voir/siehe Belgique/Belgien)

### Česká republika

Roche s. r. o.  
Tel: +420 - 2 20382111

### Magyarország

Roche (Magyarország) Kft.  
Tel: +36 - 23 446 800

### Danmark

Roche a/s  
Tlf: +45 - 36 39 99 99

### Malta

(See United Kingdom)

### Deutschland

Roche Pharma AG  
Tel: +49 (0) 7624 140

### Nederland

Roche Nederland B.V.  
Tel: +31 (0) 348 438050

### Eesti

Roche Eesti OÜ  
Tel: + 372 - 6 177 380

### Norge

Roche Norge AS  
Tlf: +47 - 22 78 90 00



**Ελλάδα**

Roche (Hellas) A.E.  
Τηλ: +30 210 61 66 100

**España**

Roche Farma S.A.  
Tel: +34 - 91 324 81 00

**France**

Roche  
Tél: +33 (0) 1 47 61 40 00

**Hrvatska**

Roche d.o.o.  
Tel: +385 1 4722 333

**Ireland**

Roche Products (Ireland) Ltd.  
Tel: +353 (0) 1 469 0700

**Ísland**

Roche a/s  
c/o Icepharma hf  
Sími: +354 540 8000

**Italia**

Roche S.p.A.  
Tel: +39 - 039 2471

**Κύπρος**

Γ.Α.Σταμάτης & Σια Λτδ.  
Τηλ: +357 - 22 76 62 76

**Latvija**

Roche Latvija SIA  
Tel: +371 - 6 7039831

**Österreich**

Roche Austria GmbH  
Tel: +43 (0) 1 27739

**Polska**

Roche Polska Sp.z o.o.  
Tel: +48 - 22 345 18 88

**Portugal**

Roche Farmacêutica Química, Lda  
Tel: +351 - 21 425 70 00

**România**

Roche România S.R.L.  
Tel: +40 21 206 47 01

**Slovenija**

Roche farmacevtska družba d.o.o.  
Tel: +386 - 1 360 26 00

**Slovenská republika**

Roche Slovensko, s.r.o.  
Tel: +421 - 2 52638201

**Suomi/Finland**

Roche Oy  
Puh/Tel: +358 (0) 10 554 500

**Sverige**

Roche AB  
Tel: +46 (0) 8 726 1200

**United Kingdom**

Roche Products Ltd.  
Tel: +44 (0) 1707 366000

**This leaflet was last revised in**

**Other sources of information**

Detailed information on this medicine is available on the European Medicines Agency web site:

<http://www.ema.europa.eu>

## 7. Instructions for use

Instructions for Use  
Hemlibra  
Injection  
Single-Dose Vial(s)

You must read, understand and follow the Instructions for Use before injecting Hemlibra. Your healthcare provider should show you how to prepare, measure, and inject Hemlibra properly before you use it for the first time. Ask your healthcare provider if you have any questions.

### Important Information:

- **Do not** inject yourself or someone else unless you have been shown how to by your healthcare provider.
- Make sure the name Hemlibra is on the box and vial label.
- Before opening the vial, read the vial label to make sure you have the correct medicine strength(s) to give the dose prescribed for you. You may need to use more than 1 vial to give yourself the correct dose.
- Check the expiry date on the box and vial label. **Do not** use if the expiry date has passed.
- **Only use the vial once.** After you inject your dose, throw away any unused Hemlibra left in the vial. Do not save unused medicine in the vial for later use.
- **Only use the syringes, transfer needles, and injection needles that your healthcare provider prescribes.**
- **Use the syringes, transfer needles and injection needles only once. Throw away any used syringes and needles.**
- If your prescribed dose is more than 2 mL, you will need to have more than one subcutaneous injection of Hemlibra; contact your healthcare provider for the injection instructions.
- You must inject Hemlibra only under the skin.

### Storing Hemlibra vials, needles and syringes:

- Keep the vial in the original box to protect the medicine from light.
- Keep the vials, needles and syringes out of the sight and reach of children. Store the vial in the refrigerator.
- **Do not** freeze.
- **Do not** shake the vial.
- Take the vial out of the refrigerator 15 minutes before use and allow it to reach room temperature (below 30 C) before preparing an injection.
- Once removed from the refrigerator, the unopened vial can be kept at room temperature for up to 7 days. After storage at room temperature unopened vials may be returned to the refrigerator. The total amount of time outside cold storage and at room temperature should not exceed 7 days.

- Discard vials that have been kept at room temperature for more than 7 days or have been in temperatures above 30°C.
- Keep the transfer needle, injection needle and syringe dry.

**Inspecting the medicine and your supplies:**

- Collect all supplies listed below to prepare and give your injection.
- **Check** the expiry date on the box, on the vial label and on the supplies listed below. **Do not use** if the expiry date has passed.
- **Do not use** the vial if:
  - the medicine is cloudy, hazy or coloured.
  - the medicine contains particles.
  - the cap covering the stopper is missing.
- Inspect the supplies for damage. **Do not use** if they appear damaged or if they have been dropped.
- Place the supplies on a clean, well-lit flat work surface.

**INCLUDED IN THE BOX:**



- **Vial containing the medicine**

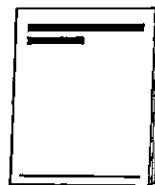

- **Instructions for Use**

NOT INCLUDED IN THE BOX:

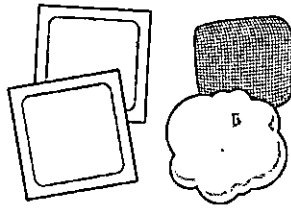

- **Alcohol wipes**

**Note:** If you need to use more than 1 vial to inject your prescribed dose, you must use a new alcohol wipe for each vial.

- **Gauze**
- **Cotton Ball**

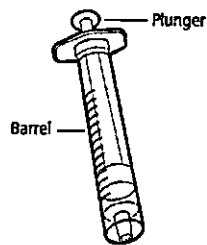

- **Syringe**

**Note:** For injection amount up to 1 mL use a **1 mL syringe**.

For injection amount between 1 mL and 2 mL use a **2 mL or 3 mL syringe**.

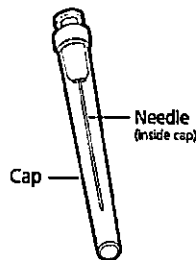

- **18G Transfer Needle**

**Note:** If you need to use more than 1 vial to inject your prescribed dose, you must use a new transfer needle for each vial.

**Do not** use the transfer needle to inject the medicine.

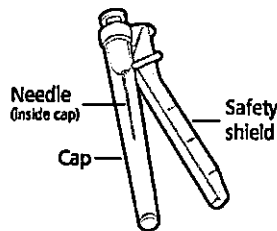

- **26G Injection Needle with safety shield**

**Do not** use the injection needle to withdraw medicine from vial.



- **Sharps disposal container**

**Get ready:**

- Before use, allow the vial(s) to reach room temperature for about 15 minutes on a clean flat surface away from direct sunlight.
- Do not try to warm the vial by any other way.
- Wash your hands well with soap and water.

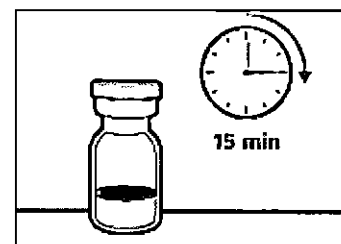

**Figure A**

**Selecting and preparing an injection site:**

- Clean the chosen injection site area using an alcohol wipe.
- Let the skin dry for about 10 seconds. Do not touch, fan or blow on the cleaned area before your injection.

**For injection, you can use your:**

- Thigh (front and middle).
- Stomach area (abdomen), except for 5 cm around the navel (belly button).
- Outer area of the upper arm (only if a caregiver is giving the injection).
- You should use a different injection site for each injection, at least 2.5 cm away from the area you used for your previous injection.
- Do not inject into areas that could be irritated by a belt or waistband. Do not inject into moles, scars, bruises, or areas where the skin is tender, red, hard or the skin is broken.

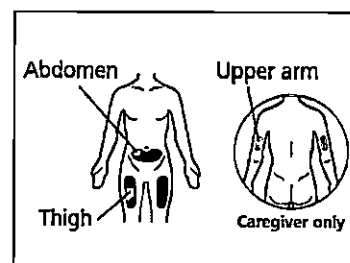

**Figure B**

**Preparing the syringe for injection:**

- Do not touch exposed needles or place them on a surface once the cap has been removed.
- Once the syringe has been filled with the medicine, the injection must be given immediately.
- Once the injection needle cap has been removed, the medicine in the syringe must be injected under the skin within 5 minutes. Do not use the syringe if the needle touches any surface
- **Throw away any used vial(s), needles, vial or injection needle caps and used syringes in a sharps or puncture-proof container.**

**Important information after the injection:**

- Do not rub the injection site after injection.
- If you see drops of blood at the injection site, you can press a sterile cotton ball or gauze over the injection site for at least 10 seconds, until bleeding has stopped.
- If you have bruising (small area of bleeding under the skin), an ice pack can also be pressed gently on the site. If bleeding does not stop, please contact your healthcare provider.

**Disposing of the medicine and supplies:**

**Important: Always keep the sharps disposal container out of reach of children.**

- Put your used needles and syringes in a sharps disposal container straight away after use. Do not throw away any loose needles and syringes in your household waste.
- If you do not have a sharps disposal container, you may use a household container that is:
  - made of heavy-duty plastic.
  - can be closed with a tight-fitting, puncture resistant lid, without sharps being able to come out.
  - upright and stable during use.
  - leak-resistant.
  - properly labelled to warn of hazardous waste inside the container.
- When your sharps disposal container is almost full, you will need to follow your local guidelines for the right way to dispose of your sharps disposal container.
- Do not throw away any used sharps disposal container in your household waste unless your local guidelines permit this. Do not recycle your used sharps disposal container.

**Step 1. Remove vial cap and clean top**

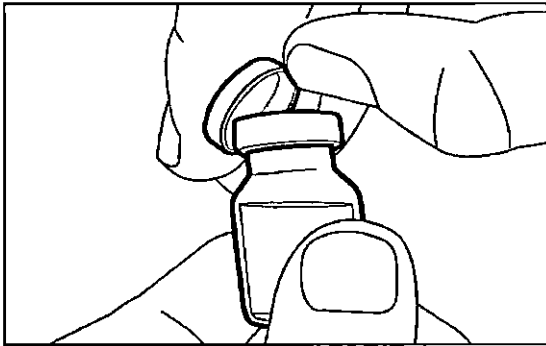

- Take the cap off the vial(s).

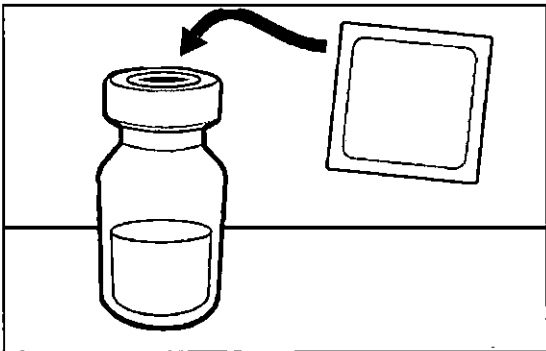

- Clean the top of the vial(s) stopper with an alcohol wipe.
- Throw away the vial cap(s) into the sharps disposal container.

**Step 2. Attach transfer needle to syringe**

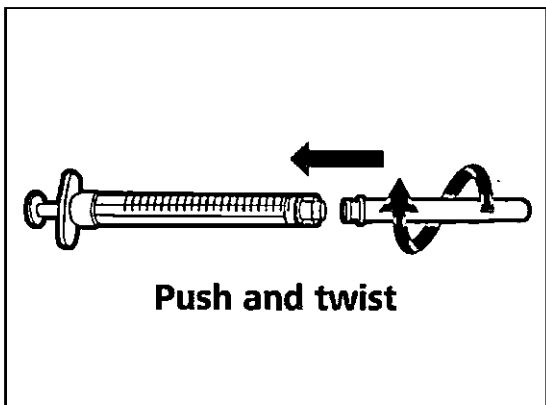

- Push and twist the transfer needle clockwise on to the syringe until it is fully attached.

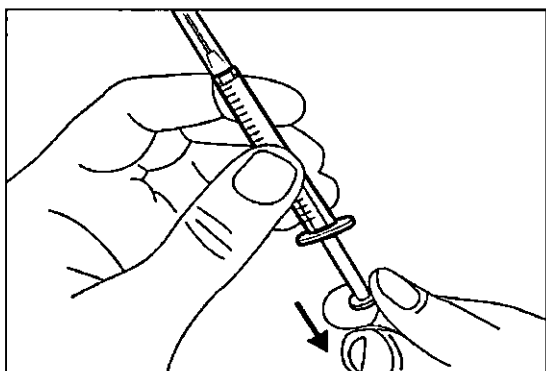

- Slowly pull back on the plunger and draw air into the syringe that is the same amount as your prescribed dose.

### Step 3. Uncap transfer needle

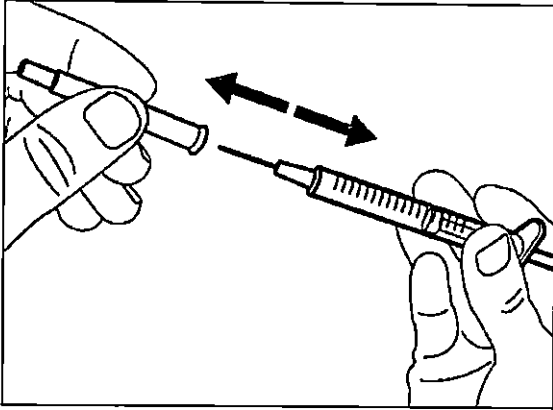

- Hold the syringe by the barrel with the transfer needle pointing up.
- Carefully pull the transfer needle cap straight off and away from your body. **Do not throw the cap away. Place the transfer needle cap down on a clean flat surface.** You will need to recap the transfer needle after transferring the medicine.
- **Do not touch** the needle tip or place it on a surface after the needle cap has been removed.

### Step 4. Inject air into vial

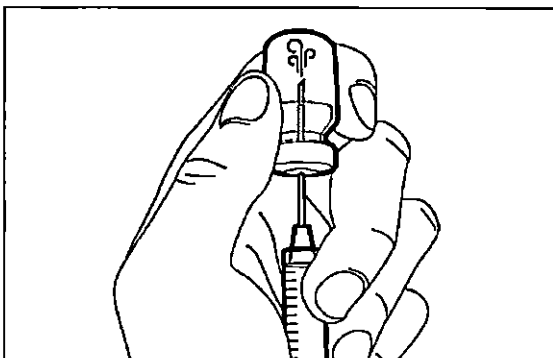
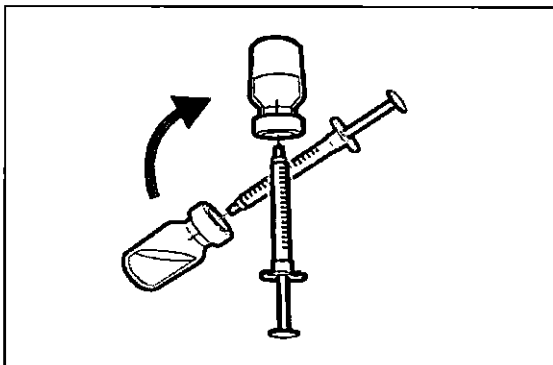
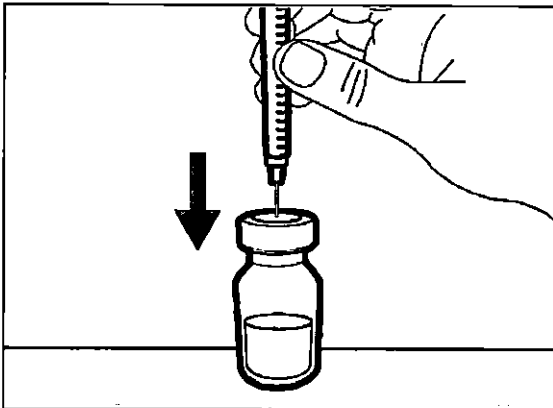

- Keep the vial on the flat working surface and insert the transfer needle and syringe straight down into the centre of the vial stopper.
- Keep the needle in the vial and turn the vial upside down.
- With the needle pointing upwards, push on the plunger to inject the air from the syringe **above the medicine.**
- Keep your finger pressed down on the syringe plunger.
- **Do not** inject air into the medicine as this could create air bubbles in the medicine.



**Step 5. Transfer medicine to syringe**

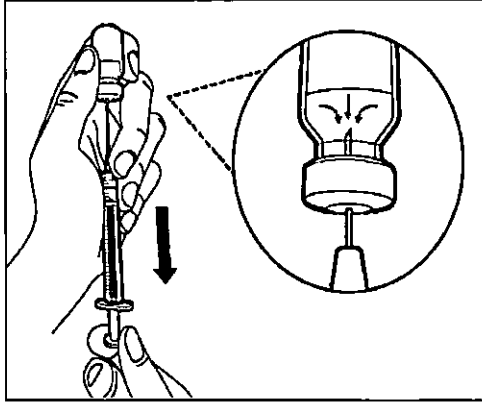

- Slide the tip of the needle down so that it is **within the medicine**.
- Slowly pull back the plunger to fill the syringe with more than the amount of medicine needed for your prescribed dose.
- Be careful not to pull the plunger out of the syringe.

**Important:** If your prescribed dose is more than the amount of medicine in the vial, **withdraw all of the medicine** and go to the “**Combining Vials**” section now.

### Step 6. Remove air bubbles

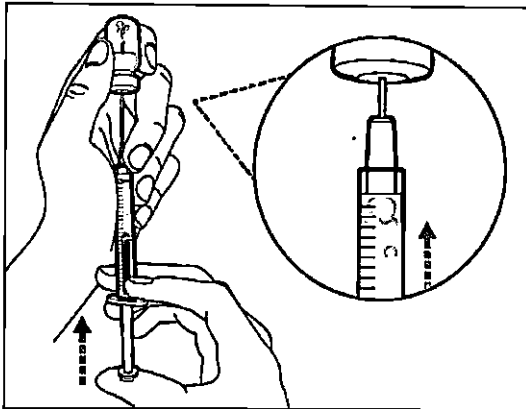

- Keep the needle in the vial and check the syringe for larger air bubbles. Large air bubble can reduce the dose you receive.
- **Remove the larger air bubbles** by gently **tapping** the syringe barrel with your fingers until the air bubbles rise to the top of the syringe. Move the tip of the needle **above the medicine** and slowly push the plunger up to push the air bubbles out of the syringe.

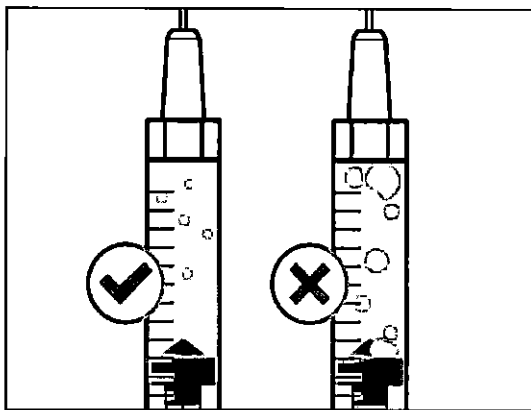

- If the amount of medicine in the syringe is now at or below your prescribed dose, move the tip of the needle to **within the medicine** and slowly **pull back** the plunger until you have **more** than the amount of medicine needed for your **prescribed dose**.
- Be careful not to pull the plunger out of the syringe.
- Repeat the steps above until you have removed the larger air bubbles.

**Note:** Ensure you have enough medicine in the syringe to complete your dose before moving onto the next step. If you cannot remove all medicine, turn the vial upright to reach the remaining amount



**Do not** use the transfer needle to inject medicine as this may cause pain and bleeding

### Step 7. Recap transfer needle

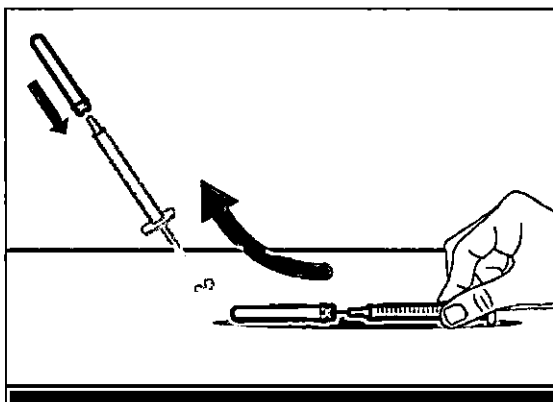

- Remove the syringe and transfer needle from the vial.
- **Using one hand**, slide the transfer needle into the cap and **scoop upwards** to cover the needle.
- Once the needle is covered, push the transfer needle cap towards the syringe to fully attach it with **one hand** to prevent accidentally injuring yourself with the needle.

**Step 8. Clean injection site**

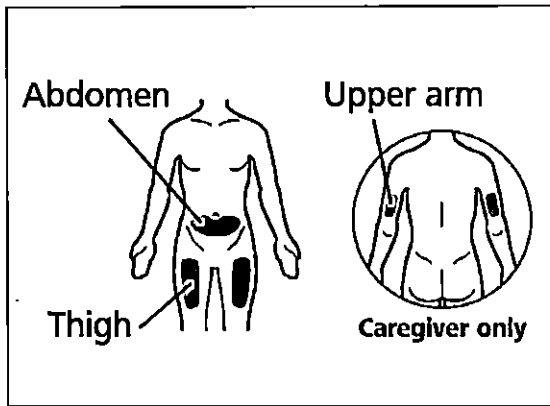

- Select and **clean** your injection site with an alcohol wipe.

**Step 9. Remove transfer needle**

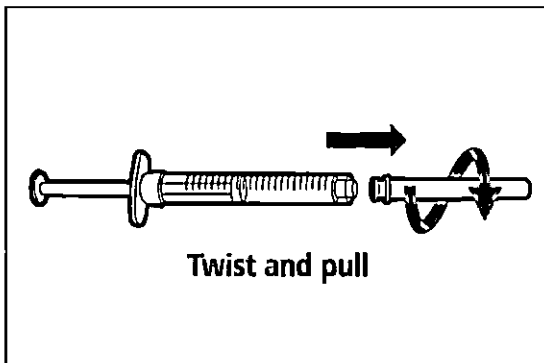

- Remove the transfer needle from the syringe by twisting anticlockwise and gently pulling.
- Throw away the used transfer needle into a sharps disposal container.

**Step 10. Attach injection needle to syringe**

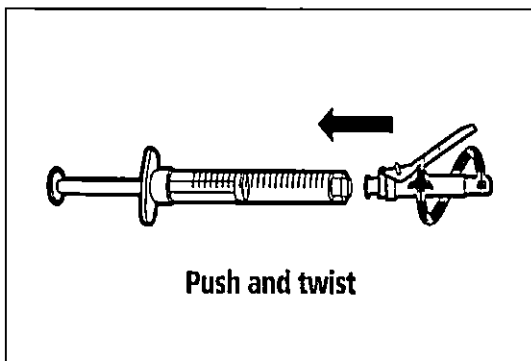

- Push and twist the injection needle clockwise onto the syringe until it is fully attached.

**Step 11. Move safety shield**

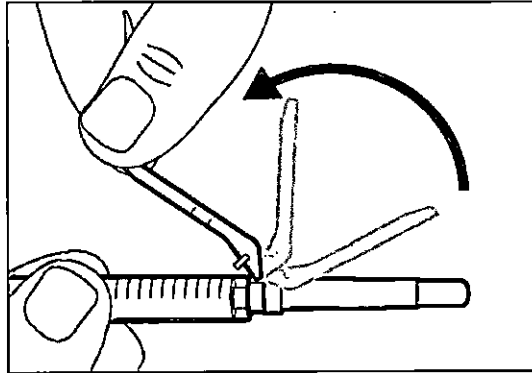

- Move the safety shield away from the needle and **towards** the syringe barrel.

**Step 12. Uncap injection needle**

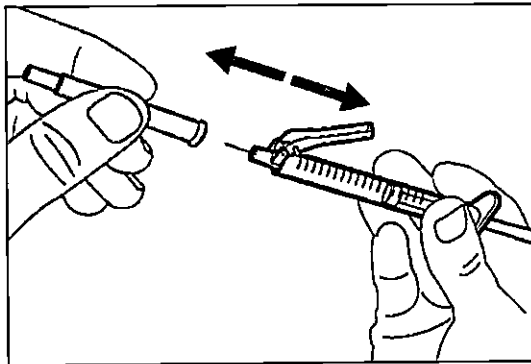

- Carefully pull the injection needle cap away from the syringe.
- Throw away the cap into a sharps disposal container.
- **Do not touch** the needle tip or allow it to touch any surface.
- After the injection needle cap has been removed, the medicine in the syringe must be injected within 5 minutes.

### Step 13. Adjust plunger to prescribed dose

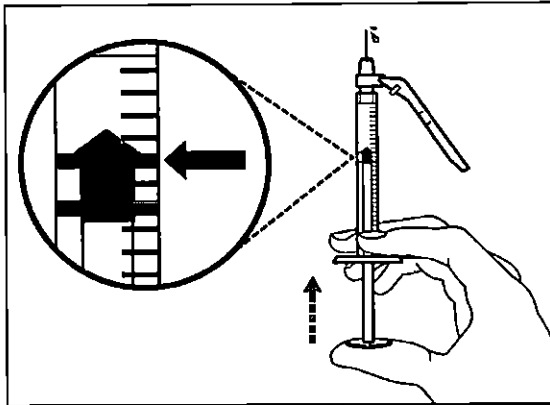

- Slowly push the plunger to your prescribed dose.
- Ensure the top rim of the plunger is in line with the mark on the syringe for your prescribed dose.

### Step 14. Subcutaneous (under the skin) injection

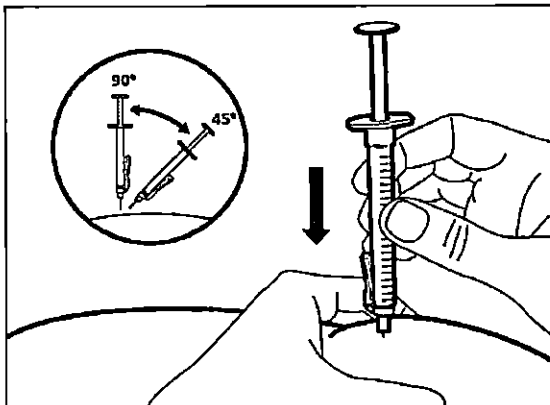

- Pinch the selected injection site and fully insert the needle at a  $45^\circ$  to  $90^\circ$  angle with a quick, firm action. **Do not** hold or push on the plunger while inserting the needle.
- Hold the position of the syringe and let go of the pinched injection site.

### Step 15. Inject the medicine

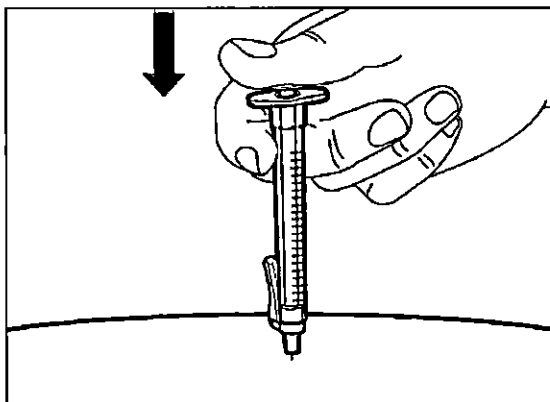

- Slowly inject all of the medicine by gently pushing the plunger all the way down.
- Remove the needle and syringe from the injection site at the same angle as inserted.

**Step 16. Cover needle with safety shield**

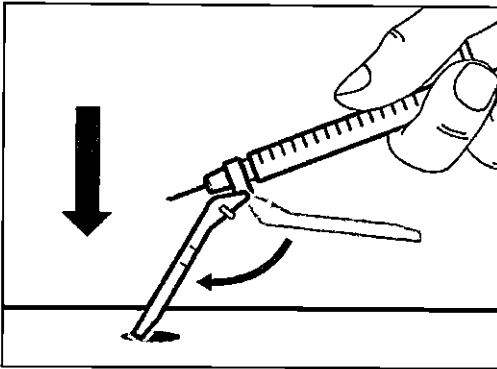

- Move the safety shield forward 90°, away from the syringe barrel.
- Holding the syringe with one hand, **press the safety shield down** against a flat surface with a firm, quick motion until you hear a “click”.

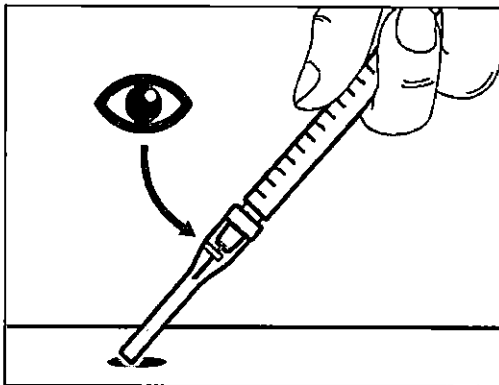

- If you do not hear a click, look to see that the needle is fully covered by the safety shield.
- Keep your fingers behind the safety shield and away from the needle at all times.
- **Do not** detach injection needle

**Step 17. Throw away the syringe and needle.**

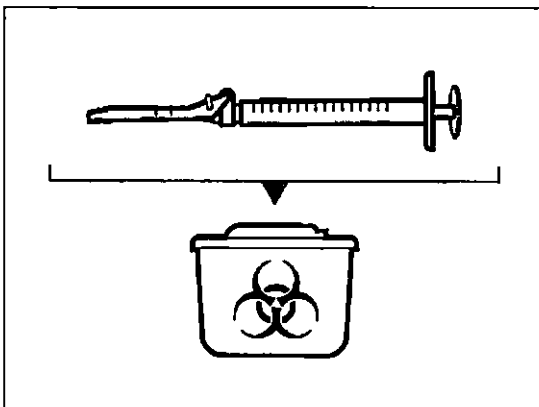

- Put **your** used needles and syringes in a sharps disposal container right away after use. For further information refer to the section “Disposing of the medicine and supplies”.
- **Do not** try to remove the used injection needle from the used syringe..
- **Do not recap** the injection needle with the cap.
- **Important:** Always keep the sharps disposal container out of reach of children.

## Combining Vials

If you need to use more than 1 vial to get to your total prescribed dose, follow these steps after you have drawn up the medicine from the first vial:

### Step A. Recap transfer needle

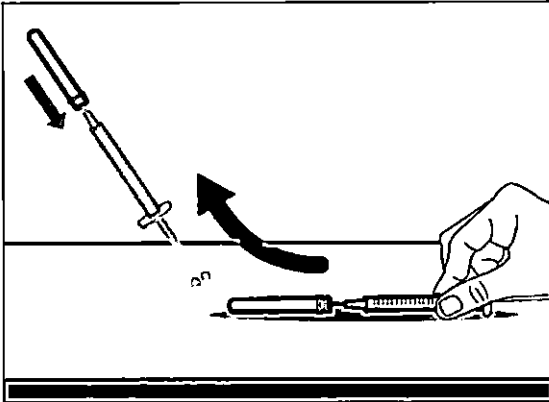

- Remove the syringe and transfer needle from the first vial.
- **Using one hand**, slide the transfer needle into the cap and **scoop upwards** to cover the needle.
- Once the needle is covered, push the transfer needle cap toward the syringe to fully attach it with **one hand** to prevent accidentally injuring yourself with the needle.

### Step B. Remove transfer needle

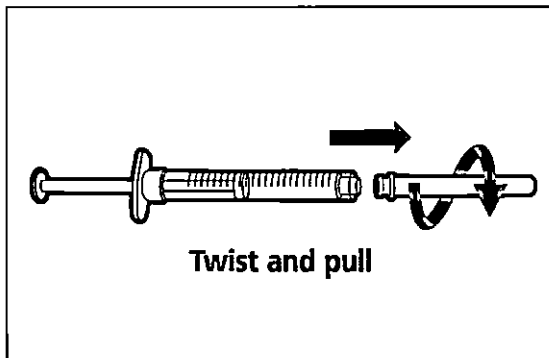

- Remove the transfer needle from the syringe by twisting anticlockwise and gently pulling.
- Throw away the used transfer needle into a sharps disposal container.

### Step C. Attach a new transfer needle to syringe

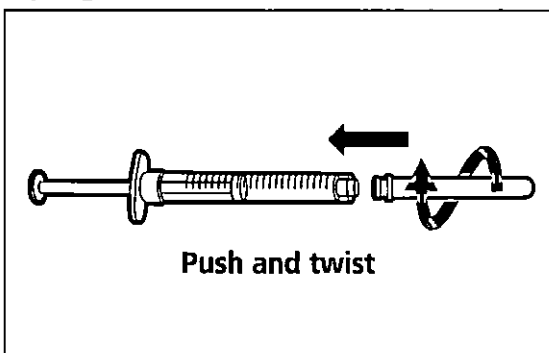

**Note: You must use a new transfer needle each time you withdraw medicine from a new vial.**

- Push and twist a **new** transfer needle clockwise on to the syringe until it is fully attached.
- Slowly pull back the plunger and draw some air into the syringe.

#### Step D. Uncap transfer needle

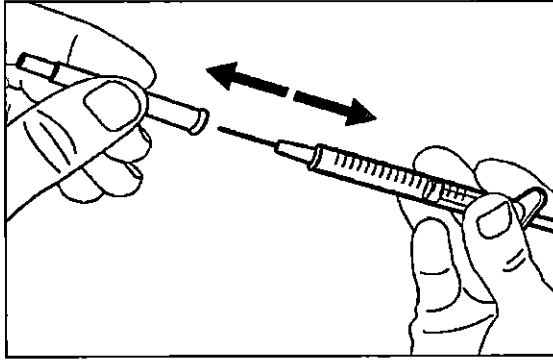

- Hold the syringe by the barrel with the transfer needle cap pointing up.
- Carefully pull the transfer needle cap straight off and away from your body. Do not throw the cap away. You will need to recap the transfer needle after drawing up the medicine.
- **Do not touch** the needle tip.

#### Step E. Inject air into vial

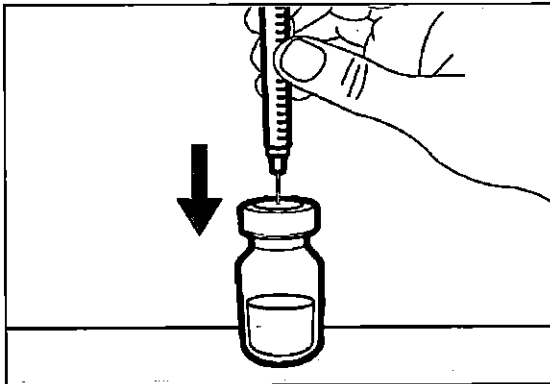

- With the new vial on the flat working surface, insert the new transfer needle and syringe, straight down into the **center** of the vial stopper.

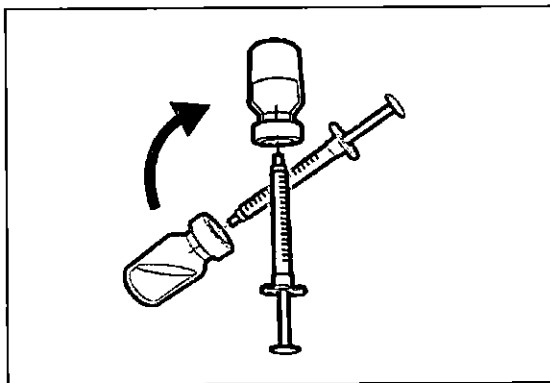

- Keep the transfer needle in the vial and turn the vial upside down.

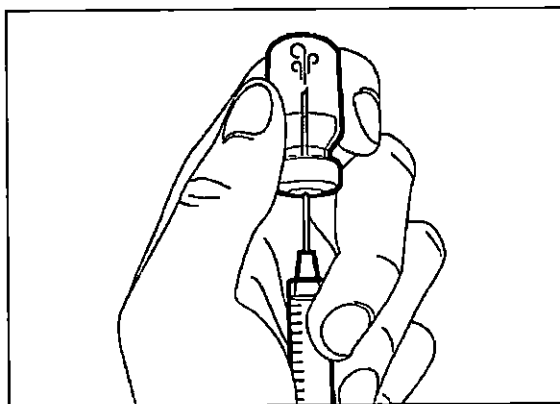

- With the needle pointing upwards, inject the air from the syringe **above the medicine**.
- Keep your finger pressed down on the syringe plunger.
- **Do not** inject air into the medicine as this could create air bubbles in the medicine.



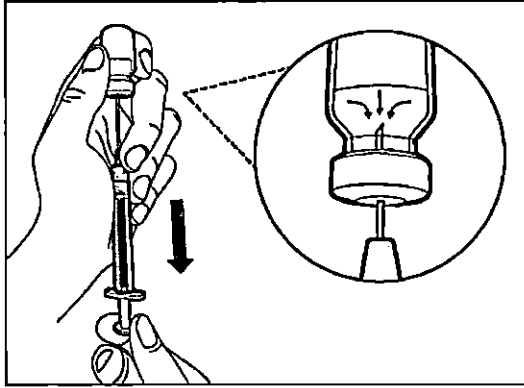

- Slide the tip of the needle down so that it is **within the medicine**.
- Slowly pull back the plunger to fill the syringe barrel more than the amount of medicine needed for your prescribed dose.
- Be careful not to pull the plunger out of the syringe.

**Note:** Ensure you have enough medicine in the syringe to complete your dose before moving onto the next steps. If you cannot remove all medicine, turn the vial upright to reach the remaining amount

**!** Do not use the transfer needle to inject medicine as this may cause harm such as pain and bleeding.

**Repeat steps A to F with each additional vial until you have more than your prescribed dose. Once completed, keep the transfer needle inserted in the vial and return to Step 6. Continue with the remaining steps.**