

เอกสารกำกับยาภาษาอังกฤษสำหรับผู้ป่วย

Package Leaflet: Information for the user

SIMPONI® SOLUTION FOR INJECTION

Simponi 45 mg/0.45 mL solution for injection in pre-filled pen

For paediatric patients below 40 kg

golimumab

Read all of this leaflet carefully before you start using this medicine because it contains important information for you.

- Keep this leaflet. You may need to read it again.
- If you have any further questions, ask your doctor, pharmacist or nurse.
- This medicine has been prescribed for you only. Do not pass it on to others. It may harm them, even if their signs of illness are the same as yours.
- If you get any side effects, talk to your doctor, pharmacist or nurse. This includes any possible side effects not listed in this leaflet. See section 4.

Your doctor will also give you a Patient Reminder Card, which contains important safety information you need to be aware of before and during your treatment with Simponi.

What is in this leaflet

1. What Simponi is and what it is used for
2. What you need to know before you use Simponi
3. How to use Simponi
4. Possible side effects
5. How to store Simponi
6. Contents of the pack and other information

1. What Simponi is and what it is used for

Simponi contains the active substance called golimumab.

Simponi belongs to a group of medicines called 'TNF blockers'. It is used **in children** 2 years of age and older for the treatment of polyarticular juvenile idiopathic arthritis.

Simponi works by blocking the action of a protein called 'tumour necrosis factor alpha' (TNF- α). This protein is involved in inflammatory processes of the body, and blocking it can reduce the inflammation in your body.

Polyarticular juvenile idiopathic arthritis

Polyarticular juvenile idiopathic arthritis is an inflammatory disease that causes joint pain and swelling in children. If you have polyarticular juvenile idiopathic arthritis you will first be given other medicines. If you do not respond well enough to these medicines, you will be given Simponi in combination with methotrexate to treat the disease.

2. What you need to know before you use Simponi

Do not use Simponi:

- If you are allergic (hypersensitive) to golimumab or any of the other ingredients of this medicine (listed in Section 6).
- If you have tuberculosis (TB) or any other severe infection.
- If you have moderate or severe heart failure.

If you are not sure if any of the above applies to you, talk to your doctor, pharmacist or nurse before using Simponi.

Warnings and precautions

Talk to your doctor, pharmacist or nurse before using Simponi.

Infections

Tell your doctor straight away if you already have or get any symptoms of infection, during or after your treatment with Simponi. Symptoms of infection include fever, cough, shortness of breath, flu-like symptoms, diarrhoea, wounds, dental problems or a burning feeling when urinating.

- You may get infections more easily while using Simponi.
- Infections may progress more rapidly and may be more severe. In addition, some previous infections may reappear.

Tuberculosis (TB)

Tell your doctor straight away if symptoms of TB appear during or after your treatment. Symptoms of TB include persistent cough, weight loss, tiredness, fever or night sweats.

- Cases of TB have been reported in patients treated with Simponi, in rare occasions even in patients who have been treated with medicines for TB. Your doctor will test you to see if you have TB. Your doctor will record these tests on your Patient Reminder Card.

- It is very important that you tell your doctor if you have ever had TB, or if you have been in close contact with someone who has had or has TB.
- If your doctor feels that you are at risk of TB, you may be treated with medicines for TB before you begin using Simponi.

Hepatitis B virus (HBV)

- Tell your doctor if you are a carrier or if you have or have had HBV before you are given Simponi.
- Tell your doctor if you think you might be at risk of contracting HBV
- Your doctor should test you for HBV
- Treatment with TNF blockers such as Simponi may result in reactivation of HBV in patients who carry this virus, which can be life-threatening in some cases.

Invasive fungal infections

If you have lived in or travelled to an area where infections caused by specific type of fungi that can affect the lungs or other parts of the body (called histoplasmosis, coccidioidomycosis, or blastomycosis), are common, tell your doctor straight away. Ask your doctor if you don't know if these fungal infections are common in the area in which you have lived or travelled.

Cancer and lymphoma

Tell your doctor if you have ever been diagnosed with lymphoma (a type of blood cancer) or any other cancer before you use Simponi.

- If you use Simponi or other TNF blockers, your risk for developing lymphoma or another cancer may increase.
- Patients with severe rheumatoid arthritis and other inflammatory diseases, who have had the disease for a long time, may be at higher than average risk of developing lymphoma.
- There have been cases of cancers, including unusual types, in children and teenage patients taking TNF-blocking agents, which sometimes resulted in death.
- On rare occasions, a specific and severe type of lymphoma called hepatosplenic T-cell lymphoma has been observed in patients taking other TNF-blockers. Most of these patients were adolescent or young adult males. This type of cancer has usually resulted in death. Almost all of these patients had also received medicines known as azathioprine or 6-mercaptopurine. Tell your doctor if you are taking azathioprine or 6-mercaptopurine with Simponi.
- Patients with severe persistent asthma, chronic obstructive pulmonary disease (COPD), or are heavy smokers may be at increased risk for cancer with Simponi treatment. If you have severe persistent asthma, COPD or are a heavy smoker, you should discuss with your doctor whether treatment with a TNF blocker is appropriate for you.
- Some patients treated with golimumab have developed certain kinds of skin cancer. If any changes in the appearance of the skin or growths on the skin occur during or after therapy, tell your doctor.

Heart failure

Tell your doctor straight away if you get new or worsening symptoms of heart failure. Symptoms of heart failure include shortness of breath or swelling of your feet.

- New and worsening congestive heart failure has been reported with TNF blockers, including Simponi. Some of these patients died.
- If you have mild heart failure and you are being treated with Simponi, you must be closely monitored by your doctor.

Nervous system disease

Tell your doctor straight away if you have ever been diagnosed with or develop symptoms of a demyelinating disease such as multiple sclerosis. Symptoms may include changes in your vision, weakness in your arms or legs or numbness or tingling in any part of your body. Your doctor will decide if you should receive Simponi.

Operations or dental procedures

- Talk to your doctor if you are going to have any operations or dental procedures.
- Tell your surgeon or dentist performing the procedure that you are having treatment with Simponi by showing them your Patient Reminder Card.

Autoimmune disease

Tell your doctor if you develop symptoms of a disease called lupus. Symptoms include persistent rash, fever, joint pain and tiredness.

- On rare occasions, people treated with TNF blockers have developed lupus.

Blood disease

In some patients the body may fail to produce enough of the blood cells that help your body fight infections or help you to stop bleeding. If you develop a fever that does not go away, bruise or bleed very easily or look very pale, call your doctor right away. Your doctor may decide to stop treatment.

If you are not sure if any of the above applies to you, talk to your doctor or pharmacist before using Simponi.

Vaccinations

Talk to your doctor if you have had, or are due to have a vaccine.

- You should not receive certain (live) vaccines while using Simponi.
- Certain vaccinations may cause infections. If you received Simponi while you were pregnant, your baby may be at higher risk for getting such an infection for up to approximately six months after the last dose you received during pregnancy. It is important that you tell your baby's doctors and other health care professionals about your Simponi use so they can decide when your baby should receive any vaccine.

Talk to your child's doctor regarding vaccinations for your child. If possible, your child should be up to date with all vaccinations before using Simponi.

Therapeutic infectious agents

Talk to your doctor if you have recently received or are scheduled to receive treatment with a therapeutic infectious agent (such as BCG instillation used for the treatment of cancer).

Allergic reactions

Tell your doctor straight away if you develop symptoms of an allergic reaction after your treatment with Simponi. Symptoms of an allergic reaction may include swelling of the face, lips, mouth or throat which may cause difficulty in swallowing or breathing, skin rash, hives, swelling of the hands, feet or ankles.

- Some of these reactions may be serious or, rarely, life-threatening.
- Some of these reactions occurred after the first administration of Simponi.

Children

Simponi is not recommended for children less than 2 years of age with polyarticular juvenile idiopathic arthritis because it has not been studied in this group.

Other medicines and Simponi

- Tell your doctor or pharmacist if you are using, have recently used or might use any other medicines, including any other medicines to treat polyarticular juvenile idiopathic arthritis.
- You should not take Simponi with medicines containing the active substance anakinra or abatacept. These medicines are used for the treatment of rheumatic diseases.
- Tell your doctor or pharmacist if you are taking any other medicines that affect your immune system.
- You should not receive certain (live) vaccines while using Simponi.

If you are not sure if any of the above applies to you, talk to your doctor or pharmacist before using Simponi.

Pregnancy and breast-feeding

Talk to your doctor before using Simponi if:

- You are pregnant or are planning to become pregnant while using Simponi. There is limited information about the effects of this medicine in pregnant women. If you are being treated with Simponi, you must avoid becoming pregnant by using adequate contraception during your treatment and for at least 6 months after the last Simponi injection. Simponi should only be used during pregnancy if it is clearly necessary for you.

- Before starting breast-feeding, your last treatment with Simponi must be at least 6 months ago. You must stop breast-feeding if you are to be given Simponi.
- If you received Simponi during your pregnancy, your baby may have a higher risk for getting an infection. It is important that you tell your baby's doctors and other health care professionals about your Simponi use before the baby receives any vaccine (for more information see section on vaccination).

If you are pregnant or breast-feeding, think you may be pregnant or are planning to have a baby, ask your doctor or pharmacist for advice before taking this medicine.

Driving and using machines

Simponi has minor influence on your ability to ride bicycles, drive and use tools or machines. Dizziness may however occur after you take Simponi. If this happens, do not ride bicycles, drive or use any tools or machines.

Simponi contains latex and sorbitol

Latex sensitivity

A part of the pre-filled pen, the needle cover, contains latex. Because latex may cause severe allergic reactions, talk to your doctor before using Simponi if you or your carer are allergic to latex.

Sorbitol intolerance

This medicine contains 18.45 mg sorbitol (E420) in each pre-filled pen. Each 0.05 mL medicine contains 2.05 mg sorbitol (E420).

3. How to use Simponi

Always use this medicine exactly as your doctor or pharmacist has told you. You should check with your doctor or pharmacist if you are not sure.

How much Simponi is given

Polyarticular juvenile idiopathic arthritis in children 2 years of age and older:

- Children weighing *less than 40 kg*:

The recommended dose of Simponi for children weighing less than 40 kg depends on their weight and height. Your doctor will tell you the correct dose to use. The dose should be given once a month, on the same date each month.

- Children weighing *at least 40 kg*:

For children with body weight of at least 40 kg, a fixed dose 50 mg pre-filled pen or pre-filled syringe is available. For the 50 mg dose, see section 3 "How to use Simponi" of the Simponi 50 mg pre-filled pen or pre-filled syringe package leaflet.

- Talk to your doctor before you take the fourth dose. Your doctor will determine if you should continue Simponi treatment.

How Simponi is given

- Simponi is given by injection under the skin (subcutaneously).
- At the start, your doctor or nurse may inject Simponi. However, you and your doctor may decide that you may inject Simponi to yourself or to your child. In this case you will get training on how to inject Simponi.

Talk to your doctor if you have any questions about giving yourself an injection. You will find detailed "Instructions for Use" included with this leaflet.

If you use more Simponi than you should

If you have used or been given too much Simponi (either by injecting too much on a single occasion, or by using it too often), talk to your doctor or pharmacist straight away. Always take the outer carton and this leaflet with you, even if it is empty.

If you forget to use Simponi

If you forget to use Simponi on your planned date, inject the forgotten dose as soon as you remember.

Do not use a double dose to make up for a forgotten dose.

When to inject your next dose:

- If you are less than 2 weeks late, inject the forgotten dose as soon as you remember and stay on your original schedule.
- If you are more than 2 weeks late, inject the forgotten dose as soon as you remember and talk to your doctor or pharmacist to ask when you need to take the next dose.

If you are not sure what to do, talk to your doctor or pharmacist.

If you stop using Simponi

If you are considering stopping Simponi, talk to your doctor or pharmacist first.

If you have any further questions on the use of this medicine, ask your doctor, pharmacist or nurse.

4. Possible side effects

Like all medicines, this medicine can cause side effects, although not everybody gets them. Some patients may experience serious side effects and may require treatment. Side effects may appear up to several months after the last injection.

Tell your doctor straight away if you notice any of the following serious side effects of Simponi which include:

- **allergic reactions which may be serious, or rarely, life-threatening (rare).** Symptoms of an allergic reaction may include swelling of the face, lips, mouth or throat which may cause difficulty in swallowing or breathing, skin rash, hives, swelling of the hands, feet or ankles. Some of these reactions occurred after the first administration of Simponi.
- **serious infections (including TB, bacterial infections including serious blood infections and pneumonia, severe fungal infections and other opportunistic infections) (common).** Symptoms of an infection can include fever, tiredness, (persistent) cough, shortness of breath, flu-like symptoms, weight loss, night sweats, diarrhoea, wounds, dental problems and a burning feeling when urinating.
- **reactivation of hepatitis B virus if you are a carrier or have had hepatitis B before (rare).** Symptoms can include yellowing of the skin and eyes, dark brown-coloured urine, right-sided abdominal pain, fever, feeling sick, being sick, and feeling very tired.
- **nervous system disease such as multiple sclerosis (rare).** Symptoms of nervous system disease can include changes in your vision, weakness in your arms or legs, numbness or tingling in any part of your body.
- **cancer of the lymph nodes (lymphoma) (rare).** Symptoms of lymphoma can include swelling of the lymph nodes, weight loss, or fever.
- **heart failure (rare).** Symptoms of heart failure can include shortness of breath or swelling of your feet.
- **signs of immune system disorders called:**
 - **lupus (rare).** Symptoms can include joint pain or a rash on cheeks or arms that is sensitive to the sun.
 - **sarcoidosis (rare).** Symptoms can include a persistent cough, being short of breath, chest pain, fever, swelling of your lymph nodes, weight loss, skin rashes, and blurred vision.
- **swelling of small blood vessels (vasculitis) (rare).** Symptoms can include fever, headache, weight loss, night sweats, rash, and nerve problems such as numbness and tingling.
- **skin cancer (uncommon).** Symptoms of skin cancer can include changes in the appearance of your skin or growths on your skin.
- **blood disease (common).** Symptoms of blood disease can include a fever that does not go away, bruising or bleeding very easily or looking very pale.
- **blood cancer (leukaemia) (rare).** Symptoms of leukaemia can include fever, feeling tired, frequent infections, easy bruising, and night sweats.

Tell your doctor straight away if you notice any of the above symptoms.

The following additional side effects have been observed with Simponi:

Very common side effects (may affect more than 1 in 10 people):

- Upper respiratory tract infections, sore throat or hoarseness, runny nose

Common side effects (may affect up to 1 in 10 people):

- Abnormal liver tests (increased liver enzymes) found during blood tests done by your doctor
- Feeling dizzy
- Headache
- Feeling numb or having a tingling feeling
- Superficial fungal infections
- Abscess
- Bacterial infections (such as cellulitis)
- Low red blood cell counts
- Low white blood cell counts
- Positive blood lupus test
- Allergic reactions
- Indigestion
- Stomach pain
- Feeling sick (nausea)
- Flu
- Bronchitis
- Sinus infection
- Cold sores
- High blood pressure
- Fever
- Asthma, shortness of breath, wheezing
- Stomach and bowel disorders which include inflammation of the stomach lining and colon which may cause fever
- Pain and ulcers in the mouth
- Injection site reactions (including redness, hardness, pain, bruising, itching, tingling and irritation)
- Hair loss
- Rash and itching of the skin
- Difficulty sleeping

- Depression
- Feeling weak
- Bone fractures
- Chest discomfort

Uncommon side effects (may affect up to 1 in 100 people):

- Kidney infection
- Cancers, including skin cancer and non-cancerous growths or lumps, including skin moles
- Skin blisters
- Severe infection throughout the body (sepsis), sometimes including low blood pressure (septic shock)
- Psoriasis (including on the palms of your hand and/or the soles of your feet and/or in the form of skin blisters)
- Low platelet count
- Combined low platelet, red, and white blood cell count
- Thyroid disorders
- Increase in blood sugar levels
- Increase in blood cholesterol levels
- Balance disorders
- Vision disturbances
- Inflamed eye (conjunctivitis)
- Eye allergy
- Sensation of heart beating irregularly
- Narrowing of the blood vessels in the heart
- Blood clots
- Flushing
- Constipation
- Chronic inflammatory condition of the lungs
- Acid reflux
- Gall stones
- Liver disorders
- Breast disorders
- Menstrual disorders

Rare side effects (may affect up to 1 in 1,000 people):

- Failure of the bone marrow to produce blood cells

- Severely decreased number of white blood cells
- Infection of the joints or the tissue around them
- Impaired healing
- Inflammation of blood vessels in internal organs
- Leukaemia
- Melanoma (a type of skin cancer)
- Merkel cell carcinoma (a type of skin cancer)
- Lichenoid reactions (itchy reddish-purple skin rash and/or threadlike white-grey lines on mucous membranes)
- Scaly, peeling skin
- Immune disorders that could affect the lungs, skin and lymph nodes (most commonly presenting as sarcoidosis)
- Pain and discolouration in the fingers or toes
- Taste disturbances
- Bladder disorders
- Kidney disorders
- Inflammation of the blood vessels in your skin which results in rash

Side effects of which the frequency is not known:

- A rare blood cancer affecting mostly young people (hepatosplenic T-cell lymphoma)
- Kaposi's sarcoma, a rare cancer related to infection with human herpes virus 8. Kaposi's sarcoma most commonly appears as purple lesions on the skin
- Worsening of a condition called dermatomyositis (seen as a skin rash accompanying muscle weakness)

Reporting of side effects

If you get any side effects, talk to your doctor, pharmacist or nurse. This includes any possible side effects not listed in this leaflet. You can also report side effects directly via [the national reporting system](#). By reporting side effects you can help provide more information on the safety of this medicine.

5. How to store Simponi

- Keep this medicine out of the sight and reach of children.
- Do not use this medicine after the expiry date which is stated on the label and the carton after "EXP". The expiry date refers to the last day of that month.
- Store in a refrigerator (2°C-8°C). Do not freeze.
- Keep the pre-filled pen in the outer carton in order to protect it from light.

- This medicine can also be stored out of the refrigerator at temperatures up to a maximum of 25°C for a single period of up to 30 days, but not beyond the original expiry date printed on the carton. Write the new expiry date on the carton including day/month/year (no more than 30 days after the medicine is removed from the refrigerator). Do not return this medicine to refrigerator if it has reached room temperature. Discard this medicine if not used by the new expiry date or the expiry date printed on the carton, whichever is earlier.
- Do not use this medicine if you notice that the liquid is not a clear to light yellow colour, cloudy, or contains foreign particles.
- Do not throw away any medicines via wastewater or household waste. Ask your doctor or pharmacist how to throw away medicines you no longer use. These measures will help to protect the environment.

6. Contents of the pack and other information

What Simponi contains

The active substance is golimumab. One 0.45 mL pre-filled pen contains 45 mg of golimumab. 1 mL contains 100 mg golimumab.

The other ingredients are sorbitol (E420), histidine, histidine hydrochloride monohydrate, polysorbate 80 and water for injections. For more information on sorbitol (E420), see Section 2.

What Simponi looks like and contents of the pack

Simponi is supplied as solution for injection in a single-use pre-filled pen, VarioJect. Simponi is available in packs containing 1 pre-filled pen.

The solution is clear to slightly opalescent (having a pearl-like shine), colourless to light yellow and may contain a few small translucent or white particles of protein. Do not use Simponi if the solution is discoloured, cloudy or you can see foreign particles in it.

For any information about this medicine, please contact the local representative of the Marketing Authorisation Holder.

This leaflet was last revised in

08-Mar-2024 (EUPIIL version 22-Jun-2023)

MARKETING AUTHORISATION NUMBER(S) AND DATE OF AUTHORIZATION

Product Name	License number	Manufactured by	Date of Authorization
SIMPONI SOLUTION FOR INJECTION	1C 1/57 (NB)	Baxter Pharmaceutical Solution LLC, Indiana, USA	24-Jan-2014

Imported by

Janssen-Cilag Ltd., Bangkok, Thailand

To report Suspected Adverse Reactions, please contact us at aepqcjacth@its.jnj.com

For any product information, please contact us at medinfosea@its.jnj.com

Please see full prescribing information at <https://ndi.fda.moph.go.th>

Instructions for Use
Simponi 45 mg/0.45 mL

solution for injection in pre-filled pen, VarioJect
For paediatric use

SINGLE-USE



Know your dose

Use the space above to record your prescribed dose.
Confirm with your doctor if you are unsure of your dose.

Important

If your doctor decides that you or a caregiver may be able to give your injections of Simponi at home, you should receive training on the right way to prepare and inject Simponi.

Please read this Instructions for Use before using the Simponi pre-filled pen and each time you get a new pre-filled pen. There may be new information.

Please also read the 'Package Leaflet: Information for the user' carefully before starting your injection. This instruction guide does not take the place of talking with your doctor about your medical condition or your treatment.

If you have not been trained, or have any questions, please contact your doctor, nurse or pharmacist.



Storage information

Store in refrigerator at 2° to 8°C.

Can be stored at room temperature (up to 25°C) for a single period up to 30 days, but not exceeding the original expiry date. Write the new expiry date on the back panel of the carton including day/month/year (no more than 30 days after the medicine is removed from the refrigerator). Do not return this medicine to refrigerator if it has reached room temperature.

Keep Simponi pre-filled pen and all medicines out of the sight and reach of children.

Overview

The pre-filled pen is a **manual** injection pen that allows you to set a specific, prescribed dose. Each pre-filled pen can deliver 0.1 mL to 0.45 mL (corresponding to 10 mg to 45 mg golimumab) in increments of 0.05 mL.

Before you begin using this pre-filled pen, you should know how to:

- Remove air bubbles
- Set prescribed dose
- **Manually press the plunger** to inject, like a syringe

The pre-filled pen is to be used only one time. Dispose of the pre-filled pen after use.

Do not attempt to use any leftover medicine in the pre-filled pen.

Do not share the pre-filled pen with anyone.

Do not shake.



Need help?

Call your doctor, nurse or pharmacist to talk about any questions you may have. For additional assistance refer to the Package Leaflet for your local representative contact information.

Plan ahead



Inspect carton

Check the expiration date ('EXP') printed or written on the back panel of the carton.

Do not use if the expiration date has passed.

Do not inject if the perforations on the carton are broken. Call your doctor or pharmacist for a new pre-filled pen.



Remove the pre-filled pen from the carton

Let the pre-filled pen sit **at room temperature for at least 30 minutes** out of reach of children.

Do not warm any other way.

You will need these supplies:

- **1 Alcohol swab**
- **1 Cotton ball** or **gauze pad**
- **1 Adhesive bandage**
- **1 Sharps container** (See Step 3)

Your pre-filled pen at-a-glance

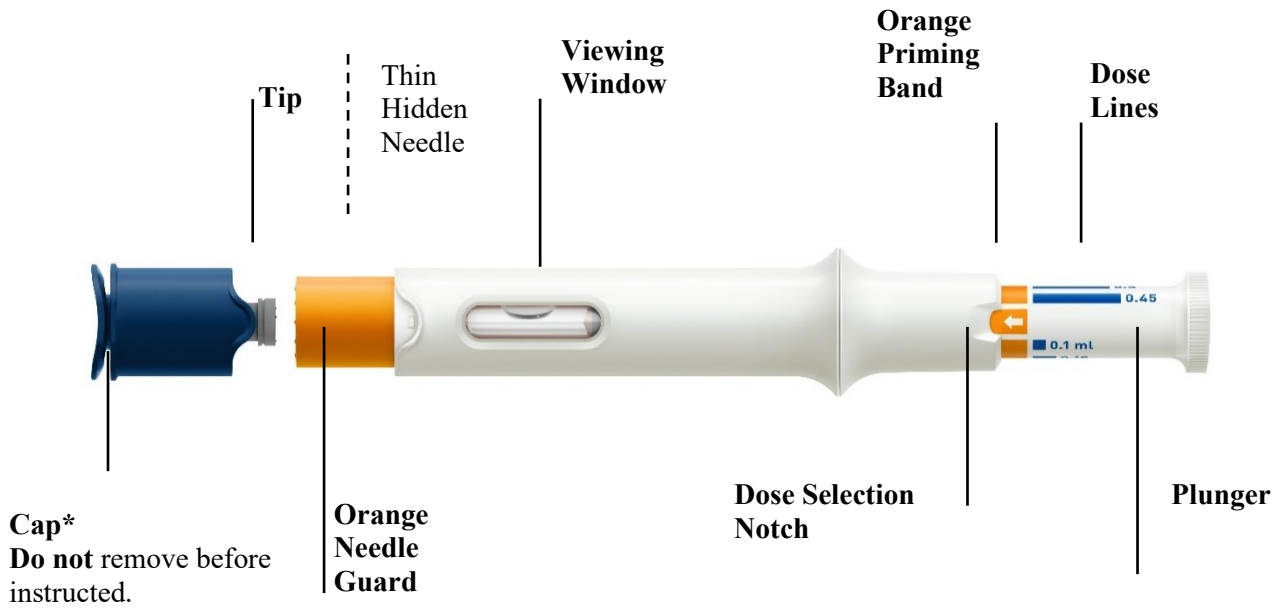

IMPORTANT:

Do not press on the orange needle guard before the injection. It will lock, and you will not receive the dose.

Do not lift the pre-filled pen from the skin during the injection. The orange needle guard will lock, and you will

*CHOKING HAZARD! Keep out of reach of children.

1. Prepare for your injection

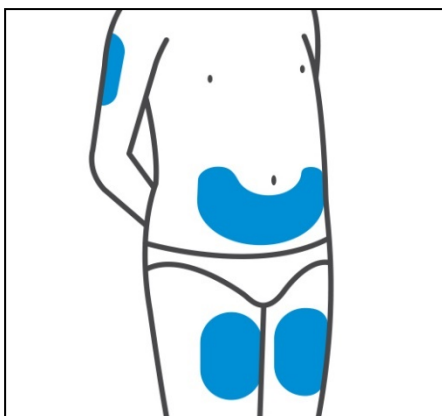

Choose injection site

Select from the following areas for your injection:

- **Front of thighs** (recommended)

- Lower abdomen
 - Do not** use the 5-centimetre area around your belly-button.
- Back of upper arms (if a caregiver is giving you the injection)

Choose a different site within your preferred area for each injection.

Do not inject into skin that is tender, bruised, red, scaly, hard or has scars.



Clean injection site

Wash your hands well with soap and warm water.

Wipe your chosen injection site with an alcohol swab and allow it to dry.

Do not touch, fan, or blow on the injection site after you have cleaned it.

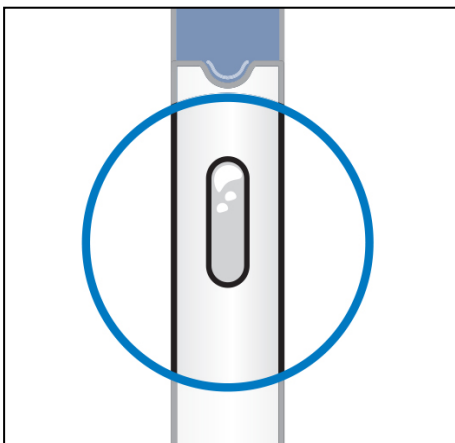

Inspect liquid

Take the pre-filled pen out of the carton.

Check the liquid in the viewing window. It should be clear to slightly opalescent (having pearl-like shine) and colourless to light yellow and may contain a few small translucent or white particles of protein. You may also see one or more air bubbles. This is normal.

Do not inject if the liquid is the wrong colour, cloudy or has large particles. If you are uncertain, call your doctor or pharmacist for a new pre-filled pen.

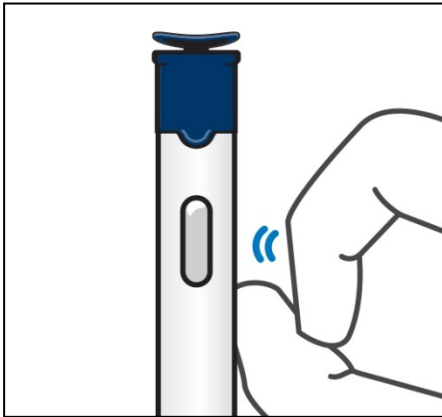

Tap air bubbles to top

Hold the pre-filled pen upright with the blue cap pointing up.

Tap the pre-filled pen gently with your finger near the viewing window. This will cause any air bubbles to rise to the top.

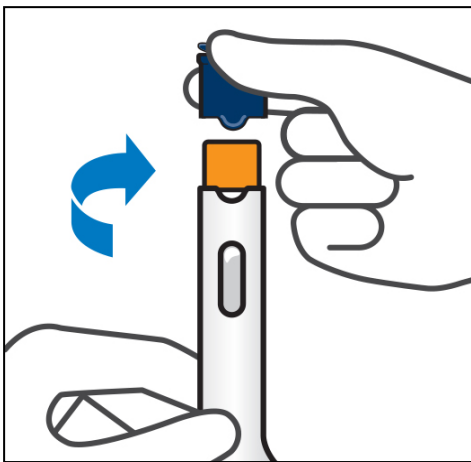

Remove cap

Keep holding the pre-filled pen upright, then twist and pull the cap to remove.

IMPORTANT: Do not press on the orange needle guard before the injection. It will lock, and you will not receive the dose.

Inject within 5 minutes of removing the cap.

Do not put the cap back on, this may damage the hidden needle.

Do not use the pre-filled pen if it is dropped without the cap on.

Call your doctor or pharmacist for a new pre-filled pen.

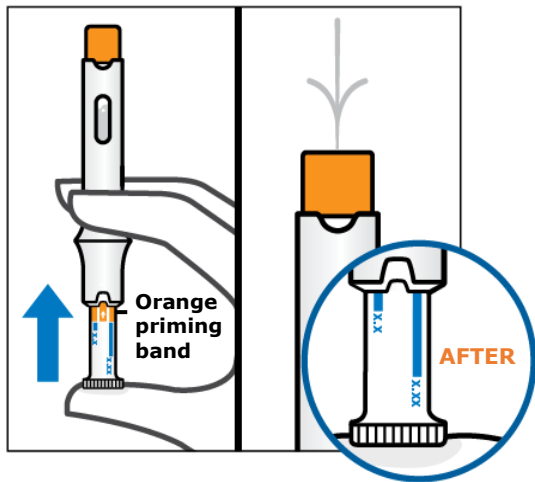

Remove air bubbles*

Keep holding the pre-filled pen upright.

Gently, press the plunger up with your thumb until it stops. Liquid will squirt out. This is normal.

The orange priming band will disappear.

**Removing air bubbles helps make sure the right dose is given.*

After you remove the air bubbles, you may see a line inside the viewing window. This is normal.

2. Inject Simponi using the pre-filled pen

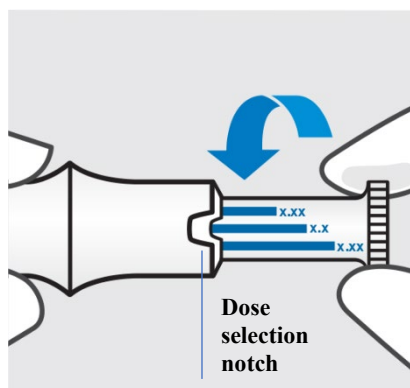

Set prescribed dose

Turn plunger until the dose line for your prescribed dose lines up with the dose selection notch. The pre-filled pen is now ready to use.

Dose selections:

0.1 mL

0.15 mL

0.2 mL

0.25 mL

0.3 mL

0.35 mL

0.4 mL

0.45 mL

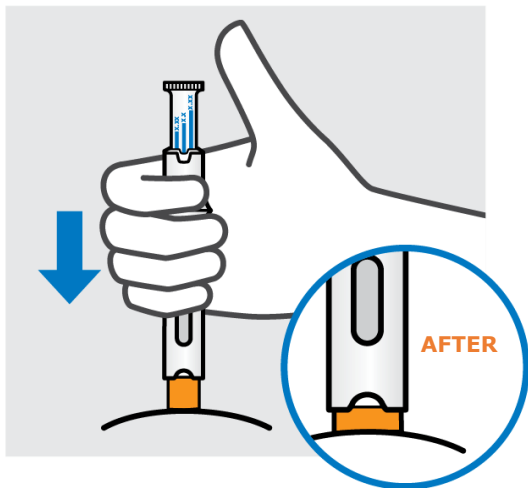

Insert needle and hold in place

IMPORTANT: Do not lift the pre-filled pen from the skin during the injection. The orange needle guard will lock, and you will not receive the full dose.

Do not press the plunger while inserting the needle.

Push and hold the pre-filled pen tip against the skin so the orange needle guard pushes up until it stops. Some orange will still be showing.

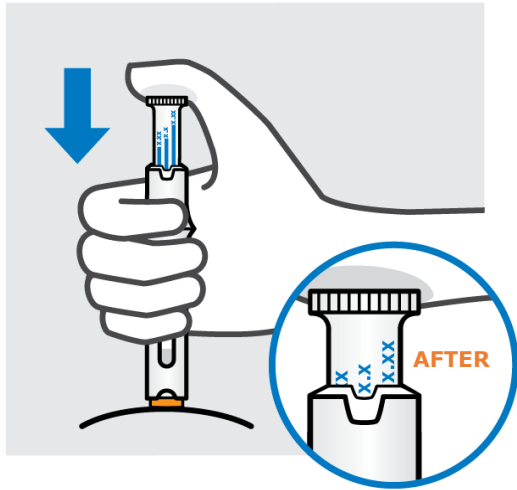

Inject Simponi

Keep pushing the pre-filled pen against the skin.

Gently, press the plunger until it stops.

If a small dose is set, the plunger will only move a short distance.

The dose you delivered can be confirmed by viewing the dose selection notch.

Do not lift the pre-filled pen up yet.

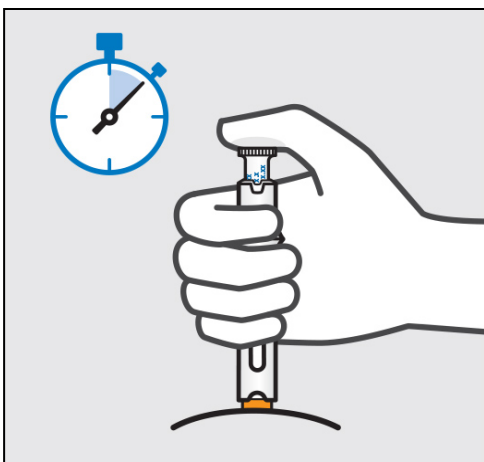

Keep holding, then lift

Keep pushing the pre-filled pen against the skin for approximately 5 seconds.

It is normal to see some drug still visible in the viewing window.

Lift the pre-filled pen away from the skin.

The orange needle guard will extend and lock.

3. After your injection



Throw the used pre-filled pen away

Put your used pre-filled pen in a sharps disposal container right away after use.

Make sure you dispose of the bin as instructed by your doctor or nurse when the container is full.

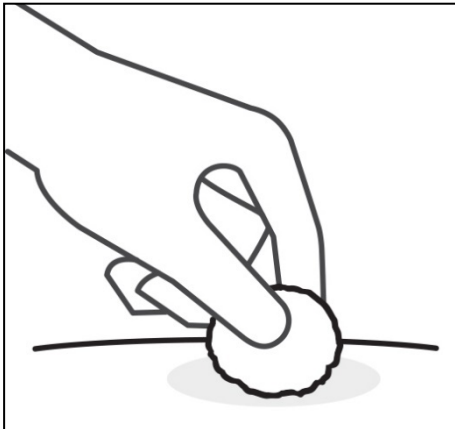

Check injection site

There may be a small amount of blood or liquid at the injection site.

Hold pressure on your skin with a cotton ball or gauze pad until any bleeding stops.

Do not rub the injection site.

If needed, cover injection site with a bandage. Your injection is now complete!

Package Leaflet: Information for the user

SIMPONI® SOLUTION FOR INJECTION

Simponi 50 mg solution for injection in pre-filled pen

golimumab

Read all of this leaflet carefully before you start using this medicine because it contains important information for you.

- Keep this leaflet. You may need to read it again.
- If you have any further questions, ask your doctor, pharmacist or nurse.
- This medicine has been prescribed for you only. Do not pass it on to others. It may harm them, even if their signs of illness are the same as yours.
- If you get any side effects, talk to your doctor, pharmacist or nurse. This includes any possible side effects not listed in this leaflet. See section 4.

Your doctor will also give you a Patient Reminder Card, which contains important safety information you need to be aware of before and during your treatment with Simponi.

What is in this leaflet

1. What Simponi is and what it is used for
2. What you need to know before you use Simponi
3. How to use Simponi
4. Possible side effects
5. How to store Simponi
6. Contents of the pack and other information

1. What Simponi is and what it is used for

Simponi contains the active substance called golimumab.

Simponi belongs to a group of medicines called 'TNF blockers'. It is used **in adults** for the treatment of the following inflammatory diseases:

- Rheumatoid arthritis
- Psoriatic arthritis
- Axial spondyloarthritis, including ankylosing spondylitis and non-radiographic axial spondyloarthritis
- Ulcerative colitis

In children 2 years of age and older, Simponi is used for the treatment of polyarticular juvenile idiopathic arthritis.

Simponi works by blocking the action of a protein called 'tumour necrosis factor alpha' (TNF- α). This protein is involved in inflammatory processes of the body, and blocking it can reduce the inflammation in your body.

Rheumatoid arthritis

Rheumatoid arthritis is an inflammatory disease of the joints. If you have active rheumatoid arthritis

you will first be given other medicines. If you do not respond well enough to these medicines, you may be given Simponi which you will take in combination with another medicine called methotrexate to:

- Reduce the signs and symptoms of your disease.
- Slow down the damage to your bones and joints.
- Improve your physical function.

Psoriatic arthritis

Psoriatic arthritis is an inflammatory disease of the joints, usually accompanied by psoriasis, an inflammatory disease of the skin. If you have active psoriatic arthritis you will first be given other medicines. If you do not respond well enough to these medicines, you may be given Simponi to:

- Reduce the signs and symptoms of your disease.
- Slow down the damage to your bones and joints.
- Improve your physical function.

Ankylosing spondylitis and non-radiographic axial spondyloarthritis

Ankylosing spondylitis and non-radiographic axial spondyloarthritis are inflammatory diseases of the spine. If you have ankylosing spondylitis or non-radiographic axial spondyloarthritis, you will first be given other medicines. If you do not respond well enough to these medicines, you may be given Simponi to:

- Reduce the signs and symptoms of your disease.
- Improve your physical function.

Ulcerative colitis

Ulcerative colitis is an inflammatory disease of the bowel. If you have ulcerative colitis you will first be given other medicines. If you do not respond well enough to these medicines, you will be given Simponi to treat your disease.

Polyarticular juvenile idiopathic arthritis

Polyarticular juvenile idiopathic arthritis is an inflammatory disease that causes joint pain and swelling in children. If you have polyarticular juvenile idiopathic arthritis you will first be given other medicines. If you do not respond well enough to these medicines, you will be given Simponi in combination with methotrexate to treat the disease.

2. What you need to know before you use Simponi

Do not use Simponi:

- If you are allergic (hypersensitive) to golimumab or any of the other ingredients of this medicine (listed in Section 6).
- If you have tuberculosis (TB) or any other severe infection.
- If you have moderate or severe heart failure.

If you are not sure if any of the above applies to you, talk to your doctor, pharmacist or nurse before using Simponi.

Warnings and precautions

Talk to your doctor, pharmacist or nurse before using Simponi.

Infections

Tell your doctor straight away if you already have or get any symptoms of infection, during or after your treatment with Simponi. Symptoms of infection include fever, cough, shortness of breath, flu-like symptoms, diarrhoea, wounds, dental problems or a burning feeling when urinating.

- You may get infections more easily while using Simponi.
- Infections may progress more rapidly and may be more severe. In addition, some previous infections may reappear.

Tuberculosis (TB)

Tell your doctor straight away if symptoms of TB appear during or after your treatment. Symptoms of TB include persistent cough, weight loss, tiredness, fever or night sweats.

- Cases of TB have been reported in patients treated with Simponi, in rare occasions even in patients who have been treated with medicines for TB. Your doctor will test you to see if you have TB. Your doctor will record these tests on your Patient Reminder Card.
- It is very important that you tell your doctor if you have ever had TB, or if you have been in close contact with someone who has had or has TB.
- If your doctor feels that you are at risk of TB, you may be treated with medicines for TB before you begin using Simponi.

Hepatitis B virus (HBV)

- Tell your doctor if you are a carrier or if you have or have had HBV before you are given Simponi.
- Tell your doctor if you think you might be at risk of contracting HBV
- Your doctor should test you for HBV
- Treatment with TNF blockers such as Simponi may result in reactivation of HBV in patients who carry this virus, which can be life-threatening in some cases.

Invasive fungal infections

If you have lived in or travelled to an area where infections caused by specific type of fungi that can affect the lungs or other parts of the body (called histoplasmosis, coccidioidomycosis, or blastomycosis), are common, tell your doctor straight away. Ask your doctor if you don't know if these fungal infections are common in the area in which you have lived or travelled.

Cancer and lymphoma

Tell your doctor if you have ever been diagnosed with lymphoma (a type of blood cancer) or any other cancer before you use Simponi.

- If you use Simponi or other TNF blockers, your risk for developing lymphoma or another cancer may increase.
- Patients with severe rheumatoid arthritis and other inflammatory diseases, who have had the disease for a long time, may be at higher than average risk of developing lymphoma.
- There have been cases of cancers, including unusual types, in children and teenage patients taking TNF-blocking agents, which sometimes resulted in death.
- On rare occasions, a specific and severe type of lymphoma called hepatosplenic T-cell lymphoma has been observed in patients taking other TNF-blockers. Most of these patients were adolescent or young adult males. This type of cancer has usually resulted in death. Almost all of these patients had also received medicines known as azathioprine or 6-mercaptopurine. Tell your doctor if you are taking azathioprine or 6-mercaptopurine with Simponi.
- Patients with severe persistent asthma, chronic obstructive pulmonary disease (COPD), or are heavy smokers may be at increased risk for cancer with Simponi treatment. If you have severe persistent asthma, COPD or are a heavy smoker, you should discuss with your doctor whether treatment with a TNF blocker is appropriate for you.
- Some patients treated with golimumab have developed certain kinds of skin cancer. If any changes in the appearance of the skin or growths on the skin occur during or after therapy, tell your doctor.

Heart failure

Tell your doctor straight away if you get new or worsening symptoms of heart failure. Symptoms of heart failure include shortness of breath or swelling of your feet.

- New and worsening congestive heart failure has been reported with TNF blockers, including Simponi. Some of these patients died.

- If you have mild heart failure and you are being treated with Simponi, you must be closely monitored by your doctor.

Nervous system disease

Tell your doctor straight away if you have ever been diagnosed with or develop symptoms of a demyelinating disease such as multiple sclerosis. Symptoms may include changes in your vision, weakness in your arms or legs or numbness or tingling in any part of your body. Your doctor will decide if you should receive Simponi.

Operations or dental procedures

- Talk to your doctor if you are going to have any operations or dental procedures.
- Tell your surgeon or dentist performing the procedure that you are having treatment with Simponi by showing them your Patient Reminder Card.

Autoimmune disease

Tell your doctor if you develop symptoms of a disease called lupus. Symptoms include persistent rash, fever, joint pain and tiredness.

- On rare occasions, people treated with TNF blockers have developed lupus.

Blood disease

In some patients the body may fail to produce enough of the blood cells that help your body fight infections or help you to stop bleeding. If you develop a fever that does not go away, bruise or bleed very easily or look very pale, call your doctor right away. Your doctor may decide to stop treatment.

If you are not sure if any of the above applies to you, talk to your doctor or pharmacist before using Simponi.

Vaccinations

Talk to your doctor if you have had, or are due to have a vaccine.

- You should not receive certain (live) vaccines while using Simponi.
- Certain vaccinations may cause infections. If you received Simponi while you were pregnant, your baby may be at higher risk for getting such an infection for up to approximately six months after the last dose you received during pregnancy. It is important that you tell your baby's doctors and other health care professionals about your Simponi use so they can decide when your baby should receive any vaccine.

Talk to your child's doctor regarding vaccinations for your child. If possible, your child should be up to date with all vaccinations before using Simponi.

Therapeutic infectious agents

Talk to your doctor if you have recently received or are scheduled to receive treatment with a therapeutic infectious agent (such as BCG instillation used for the treatment of cancer).

Allergic reactions

Tell your doctor straight away if you develop symptoms of an allergic reaction after your treatment with Simponi. Symptoms of an allergic reaction may include swelling of the face, lips, mouth or throat which may cause difficulty in swallowing or breathing, skin rash, hives, swelling of the hands, feet or ankles.

- Some of these reactions may be serious or, rarely, life-threatening.
- Some of these reactions occurred after the first administration of Simponi.

Children

Simponi is not recommended for children less than 2 years of age with polyarticular juvenile idiopathic arthritis because it has not been studied in this group.

Other medicines and Simponi

- Tell your doctor or pharmacist if you are using, have recently used or might use any other medicines, including any other medicines to treat rheumatoid arthritis, polyarticular juvenile idiopathic arthritis, psoriatic arthritis, ankylosing spondylitis, non-radiographic axial spondyloarthritis, or ulcerative colitis.
- You should not take Simponi with medicines containing the active substance anakinra or abatacept. These medicines are used for the treatment of rheumatic diseases.
- Tell your doctor or pharmacist if you are taking any other medicines that affect your immune system.
- You should not receive certain (live) vaccines while using Simponi.

If you are not sure if any of the above applies to you, talk to your doctor or pharmacist before using Simponi.

Pregnancy and breast-feeding

Talk to your doctor before using Simponi if:

- You are pregnant or are planning to become pregnant while using Simponi. There is limited information about the effects of this medicine in pregnant women. If you are being treated with Simponi, you must avoid becoming pregnant by using adequate contraception during your treatment and for at least 6 months after the last Simponi injection. Simponi should only be used during pregnancy if it is clearly necessary for you.
- Before starting breast-feeding, your last treatment with Simponi must be at least 6 months ago. You must stop breast-feeding if you are to be given Simponi.
- If you received Simponi during your pregnancy, your baby may have a higher risk for getting an infection. It is important that you tell your baby's doctors and other health

care professionals about your Simponi use before the baby receives any vaccine (for more information see section on vaccination).

If you are pregnant or breast-feeding, think you may be pregnant or are planning to have a baby, ask your doctor or pharmacist for advice before taking this medicine.

Driving and using machines

Simponi has minor influence on your ability to drive and use tools or machines. Dizziness may however occur after you take Simponi. If this happens, do not drive or use any tools or machines.

Simponi contains latex and sorbitol

Latex sensitivity

A part of the pre-filled pen, the needle cover, contains latex. Because latex may cause severe allergic reactions, talk to your doctor before using Simponi if you or your carer are allergic to latex.

Sorbitol intolerance

This medicine contains 20.5 mg sorbitol (E420) in each pre-filled pen.

3. How to use Simponi

Always use this medicine exactly as your doctor or pharmacist has told you. You should check with your doctor or pharmacist if you are not sure.

How much Simponi is given

Rheumatoid arthritis, psoriatic arthritis, and axial spondyloarthritis, including ankylosing spondylitis and non-radiographic axial spondyloarthritis:

- The recommended dose is 50 mg (the content of 1 pre-filled pen) given once a month, on the same date each month.
- Talk to your doctor before taking your fourth dose. Your doctor will determine if you should continue Simponi treatment.
 - If you weigh more than 100 kg, the dose might be increased to 100 mg (the content of 2 pre-filled pens) given once a month, on the same date each month.

Polyarticular juvenile idiopathic arthritis in children 2 years of age and older:

- For patients weighing at least 40 kg, the recommended dose is 50 mg given once a month, on the same date each month. For patients weighing less than 40 kg, a 45 mg/0.45 mL pre-filled pen is available. Your doctor will tell you the correct dose to use.
- Talk to your doctor before you take the fourth dose. Your doctor will determine if you should continue Simponi treatment.

Ulcerative colitis

- The table below shows how you will usually use this medicine.

Initial treatment	A starting dose of 200 mg (the contents of 4 pre-filled pens) followed by 100 mg (the contents of 2 pre-filled pens) 2 weeks later.
Maintenance treatment	<ul style="list-style-type: none">• In patients weighing less than 80 kg, 50 mg (the contents of 1 pre-filled pen) 4 weeks after your last treatment, then every 4 weeks thereafter. Your doctor may decide to prescribe 100 mg (the contents of 2 pre-filled pens), depending on how well Simponi works for you.• In patients weighing 80 kg or more, 100 mg (the contents of 2 pre-filled pens) 4 weeks after your last treatment, then every 4 weeks thereafter.

How Simponi is given

- Simponi is given by injection under the skin (subcutaneously).
- At the start, your doctor or nurse may inject Simponi. However, you and your doctor may decide that you may inject Simponi yourself. In this case you will get training on how to inject Simponi yourself.

Talk to your doctor if you have any questions about giving yourself an injection. You will find detailed "Instructions for Use" at the end of this leaflet.

If you use more Simponi than you should

If you have used or been given too much Simponi (either by injecting too much on a single occasion, or by using it too often), talk to your doctor or pharmacist straight away. Always take the outer carton and this leaflet with you, even if it is empty.

If you forget to use Simponi

If you forget to use Simponi on your planned date, inject the forgotten dose as soon as you remember.

Do not use a double dose to make up for a forgotten dose.

When to inject your next dose:

- If you are less than 2 weeks late, inject the forgotten dose as soon as you remember and stay on your original schedule.
- If you are more than 2 weeks late, inject the forgotten dose as soon as you remember and talk to your doctor or pharmacist to ask when you need to take the next dose.

If you are not sure what to do, talk to your doctor or pharmacist.

If you stop using Simponi

If you are considering stopping Simponi, talk to your doctor or pharmacist first.

If you have any further questions on the use of this medicine, ask your doctor, pharmacist or nurse.

4. Possible side effects

Like all medicines, this medicine can cause side effects, although not everybody gets them. Some patients may experience serious side effects and may require treatment. The risk of certain side effects is greater with the 100 mg dose compared with the 50 mg dose. Side effects may appear up to several months after the last injection.

Tell your doctor straight away if you notice any of the following serious side effects of Simponi which include:

- **allergic reactions which may be serious, or rarely, life-threatening (rare).** Symptoms of an allergic reaction may include swelling of the face, lips, mouth or throat which may cause difficulty in swallowing or breathing, skin rash, hives, swelling of the hands, feet or ankles. Some of these reactions occurred after the first administration of Simponi.
- **serious infections (including TB, bacterial infections including serious blood infections and pneumonia, severe fungal infections and other opportunistic infections) (common).** Symptoms of an infection can include fever, tiredness, (persistent) cough, shortness of breath, flu-like symptoms, weight loss, night sweats, diarrhoea, wounds, dental problems and a burning feeling when urinating.
- **reactivation of hepatitis B virus if you are a carrier or have had hepatitis B before (rare).** Symptoms can include yellowing of the skin and eyes, dark brown-coloured urine, right-sided abdominal pain, fever, feeling sick, being sick, and feeling very tired.
- **nervous system disease such as multiple sclerosis (rare).** Symptoms of nervous system disease can include changes in your vision, weakness in your arms or legs, numbness or tingling in any part of your body.
- **cancer of the lymph nodes (lymphoma) (rare).** Symptoms of lymphoma can include swelling of the lymph nodes, weight loss, or fever.
- **heart failure (rare).** Symptoms of heart failure can include shortness of breath or swelling of your feet.
- **signs of immune system disorders called:**
 - **lupus (rare).** Symptoms can include joint pain or a rash on cheeks or arms that is sensitive to the sun.
 - **sarcoidosis (rare).** Symptoms can include a persistent cough, being short of breath, chest pain, fever, swelling of your lymph nodes, weight loss, skin rashes, and blurred vision.

- **swelling of small blood vessels (vasculitis) (rare).** Symptoms can include fever, headache, weight loss, night sweats, rash, and nerve problems such as numbness and tingling.
- **skin cancer (uncommon).** Symptoms of skin cancer can include changes in the appearance of your skin or growths on your skin.
- **blood disease (common).** Symptoms of blood disease can include a fever that does not go away, bruising or bleeding very easily or looking very pale.
- **blood cancer (leukaemia) (rare).** Symptoms of leukaemia can include fever, feeling tired, frequent infections, easy bruising, and night sweats.

Tell your doctor straight away if you notice any of the above symptoms.

The following additional side effects have been observed with Simponi:

Very common side effects (may affect more than 1 in 10 people):

- Upper respiratory tract infections, sore throat or hoarseness, runny nose

Common side effects (may affect up to 1 in 10 people):

- Abnormal liver tests (increased liver enzymes) found during blood tests done by your doctor
- Feeling dizzy
- Headache
- Feeling numb or having a tingling feeling
- Superficial fungal infections
- Abscess
- Bacterial infections (such as cellulitis)
- Low red blood cell counts
- Low white blood cell counts
- Positive blood lupus test
- Allergic reactions
- Indigestion
- Stomach pain
- Feeling sick (nausea)
- Flu
- Bronchitis
- Sinus infection
- Cold sores
- High blood pressure
- Fever

- Asthma, shortness of breath, wheezing
- Stomach and bowel disorders which include inflammation of the stomach lining and colon which may cause fever
- Pain and ulcers in the mouth
- Injection site reactions (including redness, hardness, pain, bruising, itching, tingling and irritation)
- Hair loss
- Rash and itching of the skin
- Difficulty sleeping
- Depression
- Feeling weak
- Bone fractures
- Chest discomfort

Uncommon side effects (may affect up to 1 in 100 people):

- Kidney infection
- Cancers, including skin cancer and non-cancerous growths or lumps, including skin moles
- Skin blisters
- Severe infection throughout the body (sepsis), sometimes including low blood pressure (septic shock)
- Psoriasis (including on the palms of your hand and/or the soles of your feet and/or in the form of skin blisters)
- Low platelet count
- Combined low platelet, red, and white blood cell count
- Thyroid disorders
- Increase in blood sugar levels
- Increase in blood cholesterol levels
- Balance disorders
- Vision disturbances
- Inflamed eye (conjunctivitis)
- Eye allergy
- Sensation of heart beating irregularly
- Narrowing of the blood vessels in the heart
- Blood clots
- Flushing
- Constipation
- Chronic inflammatory condition of the lungs

- Acid reflux
- Gall stones
- Liver disorders
- Breast disorders
- Menstrual disorders

Rare side effects (may affect up to 1 in 1,000 people):

- Failure of the bone marrow to produce blood cells
- Severely decreased number of white blood cells
- Infection of the joints or the tissue around them
- Impaired healing
- Inflammation of blood vessels in internal organs
- Leukaemia
- Melanoma (a type of skin cancer)
- Merkel cell carcinoma (a type of skin cancer)
- Lichenoid reactions (itchy reddish-purple skin rash and/or threadlike white-grey lines on mucous membranes)
- Scaly, peeling skin
- Immune disorders that could affect the lungs, skin and lymph nodes (most commonly presenting as sarcoidosis)
- Pain and discolouration in the fingers or toes
- Taste disturbances
- Bladder disorders
- Kidney disorders
- Inflammation of the blood vessels in your skin which results in rash

Side effects of which the frequency is not known:

- A rare blood cancer affecting mostly young people (hepatosplenic T-cell lymphoma)
- Kaposi's sarcoma, a rare cancer related to infection with human herpes virus 8. Kaposi's sarcoma most commonly appears as purple lesions on the skin
- Worsening of a condition called dermatomyositis (seen as a skin rash accompanying muscle weakness)

Reporting of side effects

If you get any side effects, talk to your doctor, pharmacist or nurse. This includes any possible side effects not listed in this leaflet. You can also report side effects directly via the national reporting system. By reporting side effects you can help provide more information on the safety of this medicine.

5. How to store Simponi

- Keep this medicine out of the sight and reach of children.
- Do not use this medicine after the expiry date which is stated on the label and the carton after "EXP". The expiry date refers to the last day of that month.
- Store in a refrigerator (2°C-8°C). Do not freeze.
- Keep the pre-filled pen in the outer carton in order to protect it from light.
- This medicine can also be stored out of the refrigerator at temperatures up to a maximum of 25°C for a single period of up to 30 days, but not beyond the original expiry date printed on the carton. Write the new expiry date on the carton including day/month/year (no more than 30 days after the medicine is removed from the refrigerator). Do not return this medicine to refrigerator if it has reached room temperature. Discard this medicine if not used by the new expiry date or the expiry date printed on the carton, whichever is earlier.
- Do not use this medicine if you notice that the liquid is not a clear to light yellow colour, cloudy, or contains foreign particles.
- Do not throw away any medicines via wastewater or household waste. Ask your doctor or pharmacist how to throw away medicines you no longer use. These measures will help to protect the environment.

6. Contents of the pack and other information

What Simponi contains

The active substance is golimumab. One 0.5 mL pre-filled pen contains 50 mg of golimumab.

The other ingredients are sorbitol (E420), histidine, histidine hydrochloride monohydrate, polysorbate 80 and water for injections. For more information on sorbitol (E420), see Section 2.

What Simponi looks like and contents of the pack

Simponi is supplied as solution for injection in a single-use pre-filled pen. Simponi is available in packs containing 1 pre-filled pen and multipacks containing 3 (3 packs of 1) pre-filled pens. Not all pack sizes may be marketed.

The solution is clear to slightly opalescent (having a pearl-like shine), colourless to light yellow and may contain a few small translucent or white particles of protein. Do not use Simponi if the solution is discoloured, cloudy or you can see foreign particles in it.

This leaflet was last revised in

08-Mar-2024 (EUPIL version 22-Jun-2023)

MARKETING AUTHORISATION NUMBER(S) AND DATE OF AUTHORIZATION

Product Name	License number	Manufactured by	Date of Authorization
SIMPONI SOLUTION FOR INJECTION	1C 1/57 (NB)	Baxter Pharmaceutical Solution LLC, Indiana, USA	24-Jan-2014

Imported by

Janssen-Cilag Ltd., Bangkok, Thailand

To report Suspected Adverse Reactions, please contact us at aepgcjacth@its.jnj.com

For any product information, please contact us at medinfosea@its.jnj.com

Please see full prescribing information at <https://ndi.fda.moph.go.th>

INSTRUCTIONS FOR USE

If you would like to self inject Simponi, you must be trained by a healthcare professional to prepare an injection and give it to yourself. If you have not been trained, please contact your doctor, nurse or pharmacist to schedule a training session.

In these instructions:

1. Preparing for use of the pre-filled pen
2. Choosing and preparing the injection site
3. Injecting the medicine
4. After the injection

The diagram below (see figure 1) shows what the "SmartJect" pre-filled pen looks like.

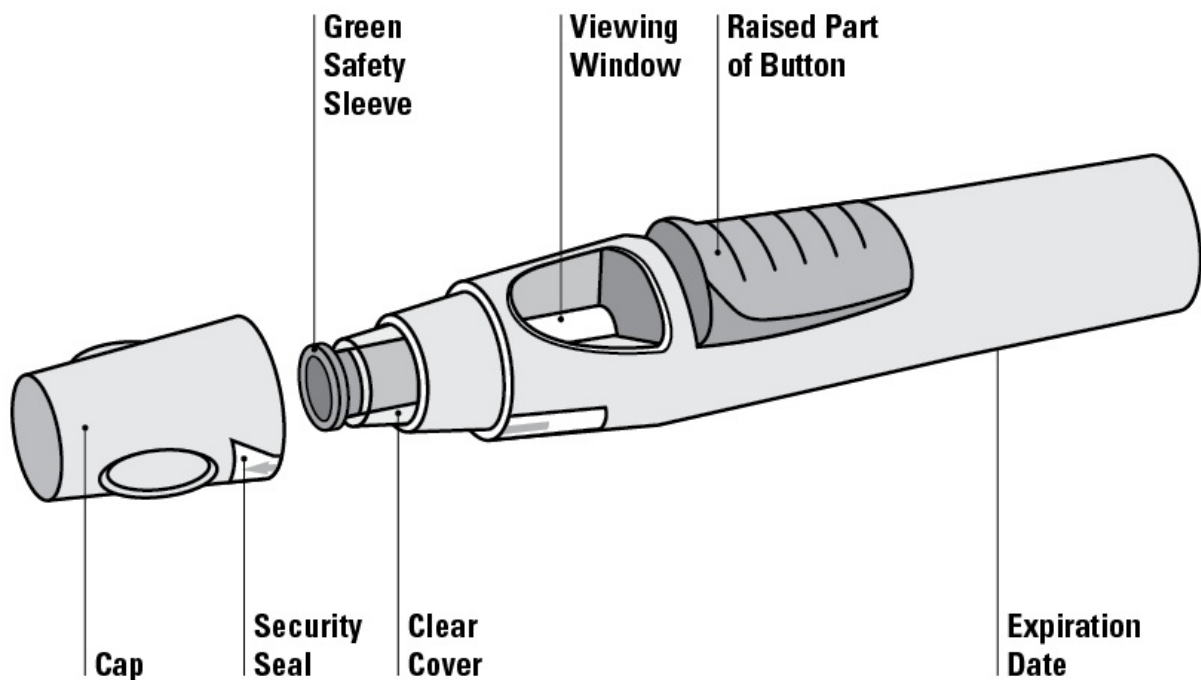

Figure 1

1. Preparing for use of the pre-filled pen

- Do not shake the pre-filled pen at any time.
- Do not remove the cap from the pre-filled pen until immediately before the injection.
- Do not put the cap of the pre-filled pen back on if removed to avoid bending the needle.

Check the number of pre-filled pens

Check the pre-filled pens to make sure

- the number of pre-filled pens and strength is correct
 - If your dose is 50 mg, you will get one 50 mg pre-filled pen
 - If your dose is 100 mg, you will get two 50 mg pre-filled pens and you will need to give yourself two injections. Choose two different sites for these injections (e.g. one injection in the right thigh and the other injection in the left thigh), and give the injections one right after the other.
 - If your dose is 200 mg, you will get four 50 mg pre-filled pens and you will need to give yourself four injections. Choose different sites for these injections and give the injections one right after the other.

Check expiry date

- Check the expiration date printed or written on the carton.
- Check the expiration date (as indicated as "EXP") on the pre-filled pen.
- Do not use the pre-filled pen if the expiration date has passed. The printed expiration date refers to the last day of the month. Please contact your doctor or pharmacist for assistance.

Check security seal

- Check the security seal around the cap of the pre-filled pen.
- Do not use the pre-filled pen if the seal is broken. Please contact your doctor or pharmacist.

Wait 30 minutes to allow pre-filled pen to reach room temperature

- To ensure proper injection, allow the pre-filled pen to sit at room temperature outside the box for 30 minutes out of the reach of children.
- Do not warm the pre-filled pen in any other way (for example, do not warm it in a microwave or in hot water).
- Do not remove the pre-filled pen's cap while allowing it to reach room temperature.

Get the rest of your equipment ready

- While you are waiting you can get the rest of your equipment ready, including an alcohol swab, a cotton ball or gauze and a sharps container.

Check the liquid in the pre-filled pen

- Look through the viewing window to make sure that the liquid in the pre-filled pen is clear to slightly opalescent (having a pearl-like shine) and colourless to light yellow. The solution can be used if it contains a few small translucent or white particles of protein.
- You will also notice an air bubble, which is normal.

- Do not use the pre-filled pen if the liquid is the wrong colour, cloudy, or contains larger particles. If this happens, talk to your doctor or pharmacist.

2. Choosing and preparing the injection site (see figure 2)

- You can inject the medicine into the front of the middle thighs.
- You can use the stomach (abdomen) below the belly button, except for approximately the 5 cm area directly underneath the belly button.
- Do not inject into areas where the skin is tender, bruised, red, scaly, hard or has scars or stretch marks.
- If multiple injections are required for a single administration, the injections should be administered at different injection sites.

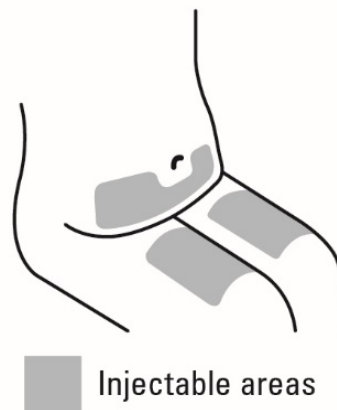

Figure 2

⚠ DO NOT inject into the arm to avoid failure of the pre-filled pen and/or unintentional injury.

Wash hands and clean the injection site

- Wash your hands thoroughly with soap and warm water.
- Wipe the injection site with an alcohol swab.
- Allow the skin to dry before injecting. Do not fan or blow on the clean area.
- Do not touch this area again before giving the injection.

3. Injecting the medicine

- The cap should not be removed until you are ready to inject the medicine.
- The medicine should be injected within 5 minutes after the cap has been removed.

Remove the cap (figure 3)

- When you are ready to inject, twist the cap slightly to break the security seal.
- Pull the cap off and throw it away after your injection.
- Do not put the cap back on because it may damage the needle inside the pre-filled pen.
- Do not use the pre-filled pen if it is dropped without the cap in place. If this happens please contact your doctor or pharmacist.

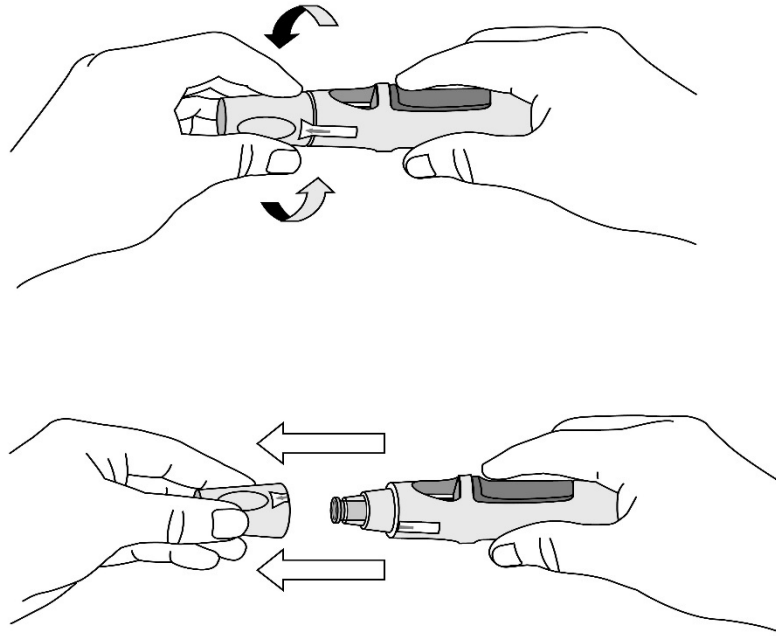

Figure 3

Push the pre-filled pen against the skin (see figures 4 and 5) without pinching the skin.



Figure 4

- Hold the pre-filled pen comfortably with one hand **above the blue button** .
- Make sure the green safety sleeve is stable and is as flat as possible against your skin. If the pre-filled pen is not stable during the injection, you risk bending the needle.

- DO NOT pinch the skin to avoid unintentional needlestick injury.
- **DO NOT** touch or press the blue button while positioning the pre-filled pen onto your skin.

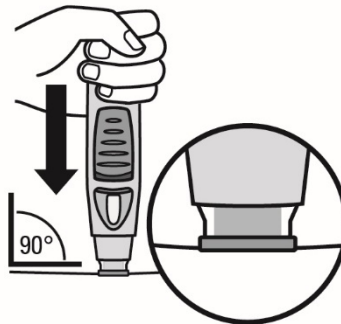

Figure 5

- Push the open end of the pre-filled pen against the skin at a 90-degree angle. Apply enough pressure to slide the green safety sleeve up and to maintain it inside the clear cover. Only the wider portion of the green safety sleeve remains outside of the clear cover.
- DO NOT press the blue button until after the safety sleeve slides into the clear cover. Pushing the blue button before the safety sleeve is depressed can lead to pen failure.
- Inject without pinching the skin.

Press button to inject (see figures 6 and 7)

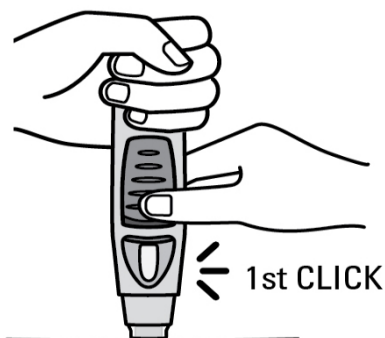

Figure 6

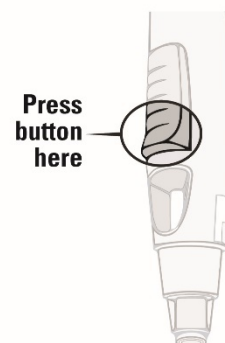

Figure 7

- Continue to push the pre-filled pen against your skin. **Use your other hand** to press the **raised part of the blue button** to start your injection. Do not press the button unless the pre-filled pen is **pressed against your skin** and the safety sleeve slides into the clear cover.

- Once the button is pressed, it will remain pressed in so you do not need to keep pressure on it.
- If the button seems hard to depress, don't press the button harder. Let go of the button, lift the pre-filled pen and start again. Ensure no pressure is on the button until the green safety sleeve is fully depressed against the skin, then press the raised part of the button.
- **You will hear a loud 'click' sound – don't be alarmed.** The first 'click' means that the needle has been inserted and the injection has started. You may or may not feel a needle prick at this time.

Do not lift the pre-filled pen away from your skin. If you pull the pre-filled pen away from your skin, you may not get your full dose of medicine.

Continue to hold until the second 'click' (see figure 8), it usually takes about 3 to 6 seconds, but may take up to 15 seconds for you to hear the second 'click' sound.

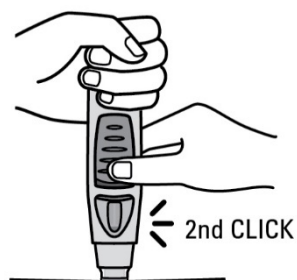

Figure 8

- **Continue to hold the pre-filled pen against your skin until you hear a second 'click' (indicating that the injection has finished and the needle has gone back into the pre-filled pen).**
- Lift the pre-filled pen from the injection site.
- Note: If you do not hear the second 'click', wait 15 seconds from the time you first press the button and then lift the autoinjector from the injection site.

4. After the injection

Use a cotton ball or gauze

- There may be a small amount of blood or liquid at the injection site. This is normal.
- You can press a cotton ball or gauze over the injection site for 10 seconds.

- You may cover the injection site with a small adhesive bandage, if necessary.
- Do not rub your skin.

Check the window – a yellow indicator confirms proper administration (see figure 9)

- The yellow indicator is connected to the plunger of the pre-filled pen. If the yellow indicator is not shown in the window, the plunger has not advanced adequately, and the injection has not occurred.
- The yellow indicator will fill about half of the viewing window. This is normal.
- Talk to your doctor or pharmacist if the yellow indicator is not visible in the window or if you suspect that you may not have received a complete dose. Do not administer a second dose without speaking to your doctor.

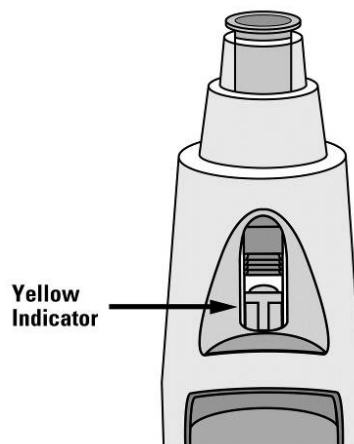

Figure 9

Throw the pre-filled pen away (see figure 10)

- Place your pen in a sharps container straight away. Make sure you dispose of the bin as instructed by your doctor or nurse when the container is full.

If you feel that something has gone wrong with the injection or if you are not sure, talk to your doctor or pharmacist.

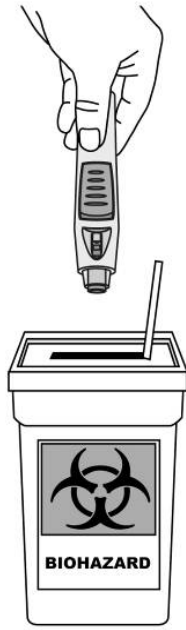

Figure 10

Package Leaflet: Information for the user

SIMPONI® SOLUTION FOR INJECTION

Simponi 50 mg solution for injection in pre-filled syringe

golimumab

Read all of this leaflet carefully before you start using this medicine because it contains important information for you.

- Keep this leaflet. You may need to read it again.
- If you have any further questions, ask your doctor, pharmacist or nurse.
- This medicine has been prescribed for you only. Do not pass it on to others. It may harm them, even if their signs of illness are the same as yours.
- If you get any side effects, talk to your doctor, pharmacist or nurse. This includes any possible side effects not listed in this leaflet. See section 4.

Your doctor will also give you a Patient Reminder Card, which contains important safety information you need to be aware of before and during your treatment with Simponi.

What is in this leaflet

1. What Simponi is and what it is used for
2. What you need to know before you use Simponi
3. How to use Simponi
4. Possible side effects
5. How to store Simponi
6. Contents of the pack and other information

1. What Simponi is and what it is used for

Simponi contains the active substance called golimumab.

Simponi belongs to a group of medicines called 'TNF blockers'. It is used **in adults** for the treatment of the following inflammatory diseases:

- Rheumatoid arthritis
- Psoriatic arthritis
- Axial spondyloarthritis, including ankylosing spondylitis and non-radiographic axial spondyloarthritis
- Ulcerative colitis

In children 2 years of age and older, Simponi is used for the treatment of polyarticular juvenile idiopathic arthritis.

Simponi works by blocking the action of a protein called 'tumour necrosis factor alpha' (TNF- α). This protein is involved in inflammatory processes of the body, and blocking it can reduce the inflammation in your body.

Rheumatoid arthritis

Rheumatoid arthritis is an inflammatory disease of the joints. If you have active rheumatoid arthritis

you will first be given other medicines. If you do not respond well enough to these medicines, you may be given Simponi which you will take in combination with another medicine called methotrexate to:

- Reduce the signs and symptoms of your disease.
- Slow down the damage to your bones and joints.
- Improve your physical function.

Psoriatic arthritis

Psoriatic arthritis is an inflammatory disease of the joints, usually accompanied by psoriasis, an inflammatory disease of the skin. If you have active psoriatic arthritis you will first be given other medicines. If you do not respond well enough to these medicines, you may be given Simponi to:

- Reduce the signs and symptoms of your disease.
- Slow down the damage to your bones and joints.
- Improve your physical function.

Ankylosing spondylitis and non-radiographic axial spondyloarthritis

Ankylosing spondylitis and non-radiographic axial spondyloarthritis are inflammatory diseases of the spine. If you have ankylosing spondylitis or non-radiographic axial spondyloarthritis, you will first be given other medicines. If you do not respond well enough to these medicines, you may be given Simponi to:

- Reduce the signs and symptoms of your disease.
- Improve your physical function.

Ulcerative colitis

Ulcerative colitis is an inflammatory disease of the bowel. If you have ulcerative colitis you will first be given other medicines. If you do not respond well enough to these medicines, you will be given Simponi to treat your disease.

Polyarticular juvenile idiopathic arthritis

Polyarticular juvenile idiopathic arthritis is an inflammatory disease that causes joint pain and swelling in children. If you have polyarticular juvenile idiopathic arthritis you will first be given other medicines. If you do not respond well enough to these medicines, you will be given Simponi in combination with methotrexate to treat the disease.

2. What you need to know before you use Simponi

Do not use Simponi:

- If you are allergic (hypersensitive) to golimumab or any of the other ingredients of this medicine (listed in Section 6).
- If you have tuberculosis (TB) or any other severe infection.
- If you have moderate or severe heart failure.

If you are not sure if any of the above applies to you, talk to your doctor, pharmacist or nurse before using Simponi.

Warnings and precautions

Talk to your doctor, pharmacist or nurse before using Simponi.

Infections

Tell your doctor straight away if you already have or get any symptoms of infection, during or after your treatment with Simponi. Symptoms of infection include fever, cough, shortness of breath, flu-like symptoms, diarrhoea, wounds, dental problems or a burning feeling when urinating.

- You may get infections more easily while using Simponi.
- Infections may progress more rapidly and may be more severe. In addition, some previous infections may reappear.

Tuberculosis (TB)

Tell your doctor straight away if symptoms of TB appear during or after your treatment. Symptoms of TB include persistent cough, weight loss, tiredness, fever or night sweats.

- Cases of TB have been reported in patients treated with Simponi, in rare occasions even in patients who have been treated with medicines for TB. Your doctor will test you to see if you have TB. Your doctor will record these tests on your Patient Reminder Card.
- It is very important that you tell your doctor if you have ever had TB, or if you have been in close contact with someone who has had or has TB.
- If your doctor feels that you are at risk of TB, you may be treated with medicines for TB before you begin using Simponi.

Hepatitis B virus (HBV)

- Tell your doctor if you are a carrier or if you have or have had HBV before you are given Simponi.
- Tell your doctor if you think you might be at risk of contracting HBV
- Your doctor should test you for HBV
- Treatment with TNF blockers such as Simponi may result in reactivation of HBV in patients who carry this virus, which can be life-threatening in some cases.

Invasive fungal infections

If you have lived in or travelled to an area where infections caused by specific type of fungi that can affect the lungs or other parts of the body (called histoplasmosis, coccidioidomycosis, or blastomycosis), are common, tell your doctor straight away. Ask your doctor if you don't know if these fungal infections are common in the area in which you have lived or travelled.

Cancer and lymphoma

Tell your doctor if you have ever been diagnosed with lymphoma (a type of blood cancer) or any other cancer before you use Simponi.

- If you use Simponi or other TNF blockers, your risk for developing lymphoma or another cancer may increase.
- Patients with severe rheumatoid arthritis and other inflammatory diseases, who have had the disease for a long time, may be at higher than average risk of developing lymphoma.
- There have been cases of cancers, including unusual types, in children and teenage patients taking TNF-blocking agents, which sometimes resulted in death.
- On rare occasions, a specific and severe type of lymphoma called hepatosplenic T-cell lymphoma has been observed in patients taking other TNF-blockers. Most of these patients were adolescent or young adult males. This type of cancer has usually resulted in death. Almost all of these patients had also received medicines known as azathioprine or 6-mercaptopurine. Tell your doctor if you are taking azathioprine or 6-mercaptopurine with Simponi.
- Patients with severe persistent asthma, chronic obstructive pulmonary disease (COPD), or are heavy smokers may be at increased risk for cancer with Simponi treatment. If you have severe persistent asthma, COPD or are a heavy smoker, you should discuss with your doctor whether treatment with a TNF blocker is appropriate for you.
- Some patients treated with golimumab have developed certain kinds of skin cancer. If any changes in the appearance of the skin or growths on the skin occur during or after therapy, tell your doctor.

Heart failure

Tell your doctor straight away if you get new or worsening symptoms of heart failure. Symptoms of heart failure include shortness of breath or swelling of your feet.

- New and worsening congestive heart failure has been reported with TNF blockers, including Simponi. Some of these patients died.

- If you have mild heart failure and you are being treated with Simponi, you must be closely monitored by your doctor.

Nervous system disease

Tell your doctor straight away if you have ever been diagnosed with or develop symptoms of a demyelinating disease such as multiple sclerosis. Symptoms may include changes in your vision, weakness in your arms or legs or numbness or tingling in any part of your body. Your doctor will decide if you should receive Simponi.

Operations or dental procedures

- Talk to your doctor if you are going to have any operations or dental procedures.
- Tell your surgeon or dentist performing the procedure that you are having treatment with Simponi by showing them your Patient Reminder Card.

Autoimmune disease

Tell your doctor if you develop symptoms of a disease called lupus. Symptoms include persistent rash, fever, joint pain and tiredness.

- On rare occasions, people treated with TNF blockers have developed lupus.

Blood disease

In some patients the body may fail to produce enough of the blood cells that help your body fight infections or help you to stop bleeding. If you develop a fever that does not go away, bruise or bleed very easily or look very pale, call your doctor right away. Your doctor may decide to stop treatment.

If you are not sure if any of the above applies to you, talk to your doctor or pharmacist before using Simponi.

Vaccinations

Talk to your doctor if you have had, or are due to have a vaccine.

- You should not receive certain (live) vaccines while using Simponi.
- Certain vaccinations may cause infections. If you received Simponi while you were pregnant, your baby may be at higher risk for getting such an infection for up to approximately six months after the last dose you received during pregnancy. It is important that you tell your baby's doctors and other health care professionals about your Simponi use so they can decide when your baby should receive any vaccine.

Talk to your child's doctor regarding vaccinations for your child. If possible, your child should be up to date with all vaccinations before using Simponi.

Therapeutic infectious agents

Talk to your doctor if you have recently received or are scheduled to receive treatment with a therapeutic infectious agent (such as BCG instillation used for the treatment of cancer).

Allergic reactions

Tell your doctor straight away if you develop symptoms of an allergic reaction after your treatment with Simponi. Symptoms of an allergic reaction may include swelling of the face, lips, mouth or throat which may cause difficulty in swallowing or breathing, skin rash, hives, swelling of the hands, feet or ankles.

- Some of these reactions may be serious or, rarely, life-threatening.
- Some of these reactions occurred after the first administration of Simponi.

Children

Simponi is not recommended for children less than 2 years of age with polyarticular juvenile idiopathic arthritis because it has not been studied in this group.

Other medicines and Simponi

- Tell your doctor or pharmacist if you are using, have recently used or might use any other medicines, including any other medicines to treat rheumatoid arthritis, polyarticular juvenile idiopathic arthritis, psoriatic arthritis, ankylosing spondylitis, non-radiographic axial spondyloarthritis, or ulcerative colitis.
- You should not take Simponi with medicines containing the active substance anakinra or abatacept. These medicines are used for the treatment of rheumatic diseases.
- Tell your doctor or pharmacist if you are taking any other medicines that affect your immune system.
- You should not receive certain (live) vaccines while using Simponi.

If you are not sure if any of the above applies to you, talk to your doctor or pharmacist before using Simponi.

Pregnancy and breast-feeding

Talk to your doctor before using Simponi if:

- You are pregnant or are planning to become pregnant while using Simponi. There is limited information about the effects of this medicine in pregnant women. If you are being treated with Simponi, you must avoid becoming pregnant by using adequate contraception during your treatment and for at least 6 months after the last Simponi injection. Simponi should only be used during pregnancy if it is clearly necessary for you.
- Before starting breast-feeding, your last treatment with Simponi must be at least 6 months ago. You must stop breast-feeding if you are to be given Simponi.
- If you received Simponi during your pregnancy, your baby may have a higher risk for getting an infection. It is important that you tell your baby's doctors and other health

care professionals about your Simponi use before the baby receives any vaccine (for more information see section on vaccination).

If you are pregnant or breast-feeding, think you may be pregnant or are planning to have a baby, ask your doctor or pharmacist for advice before taking this medicine.

Driving and using machines

Simponi has minor influence on your ability to drive and use tools or machines. Dizziness may however occur after you take Simponi. If this happens, do not drive or use any tools or machines.

Simponi contains latex and sorbitol

Latex sensitivity

A part of the pre-filled syringe, the needle cover, contains latex. Because latex may cause severe allergic reactions, talk to your doctor before using Simponi if you or your carer are allergic to latex.

Sorbitol intolerance

This medicine contains 20.5 mg sorbitol (E420) in each pre-filled syringe.

3. How to use Simponi

Always use this medicine exactly as your doctor or pharmacist has told you. You should check with your doctor or pharmacist if you are not sure.

How much Simponi is given

Rheumatoid arthritis, psoriatic arthritis, and axial spondyloarthritis, including ankylosing spondylitis and non-radiographic axial spondyloarthritis:

- The recommended dose is 50 mg (the content of 1 pre-filled syringe) given once a month, on the same date each month.
- Talk to your doctor before taking your fourth dose. Your doctor will determine if you should continue Simponi treatment.
 - If you weigh more than 100 kg, the dose might be increased to 100 mg (the content of 2 pre-filled syringes) given once a month, on the same date each month.

Polyarticular juvenile idiopathic arthritis:

- For patients weighing at least 40 kg, the recommended dose is 50 mg given once a month, on the same date each month. For patients weighing less than 40 kg, a 45 mg/0.45 mL pre-filled pen is available. Your doctor will tell you the correct dose to use.
- Talk to your doctor before you take the fourth dose. Your doctor will determine if you should continue Simponi treatment.

Ulcerative colitis

- The table below shows how you will usually use this medicine.

Initial treatment	A starting dose of 200 mg (the contents of 4 pre-filled syringes) followed by 100 mg (the contents of 2 pre-filled syringes) 2 weeks later.
Maintenance treatment	<ul style="list-style-type: none">• In patients weighing less than 80 kg, 50 mg (the contents of 1 pre-filled syringe) 4 weeks after your last treatment, then every 4 weeks thereafter. Your doctor may decide to prescribe 100 mg (the contents of 2 pre-filled syringes), depending on how well Simponi works for you.• In patients weighing 80 kg or more, 100 mg (the contents of 2 pre-filled syringes) 4 weeks after your last treatment, then every 4 weeks thereafter.

How Simponi is given

- Simponi is given by injection under the skin (subcutaneously).
- At the start, your doctor or nurse may inject Simponi. However, you and your doctor may decide that you may inject Simponi yourself. In this case you will get training on how to inject Simponi yourself.

Talk to your doctor if you have any questions about giving yourself an injection. You will find detailed "Instructions for Use" at the end of this leaflet.

If you use more Simponi than you should

If you have used or been given too much Simponi (either by injecting too much on a single occasion, or by using it too often), talk to your doctor or pharmacist straight away. Always take the outer carton and this leaflet with you, even if it is empty.

If you forget to use Simponi

If you forget to use Simponi on your planned date, inject the forgotten dose as soon as you remember.

Do not use a double dose to make up for a forgotten dose.

When to inject your next dose:

- If you are less than 2 weeks late, inject the forgotten dose as soon as you remember and stay on your original schedule.
- If you are more than 2 weeks late, inject the forgotten dose as soon as you remember and talk to your doctor or pharmacist to ask when you need to take the next dose.

If you are not sure what to do, talk to your doctor or pharmacist.

If you stop using Simponi

If you are considering stopping Simponi, talk to your doctor or pharmacist first.

If you have any further questions on the use of this medicine, ask your doctor, pharmacist or nurse.

4. Possible side effects

Like all medicines, this medicine can cause side effects, although not everybody gets them. Some patients may experience serious side effects and may require treatment. The risk of certain side effects is greater with the 100 mg dose compared with the 50 mg dose. Side effects may appear up to several months after the last injection.

Tell your doctor straight away if you notice any of the following serious side effects of Simponi which include:

- **allergic reactions which may be serious, or rarely, life-threatening (rare).** Symptoms of an allergic reaction may include swelling of the face, lips, mouth or throat which may cause difficulty in swallowing or breathing, skin rash, hives, swelling of the hands, feet or ankles. Some of these reactions occurred after the first administration of Simponi.
- **serious infections (including TB, bacterial infections including serious blood infections and pneumonia, severe fungal infections and other opportunistic infections) (common).** Symptoms of an infection can include fever, tiredness, (persistent) cough, shortness of breath, flu-like symptoms, weight loss, night sweats, diarrhoea, wounds, dental problems and a burning feeling when urinating.
- **reactivation of hepatitis B virus if you are a carrier or have had hepatitis B before (rare).** Symptoms can include yellowing of the skin and eyes, dark brown-coloured urine, right-sided abdominal pain, fever, feeling sick, being sick, and feeling very tired.
- **nervous system disease such as multiple sclerosis (rare).** Symptoms of nervous system disease can include changes in your vision, weakness in your arms or legs, numbness or tingling in any part of your body.
- **cancer of the lymph nodes (lymphoma) (rare).** Symptoms of lymphoma can include swelling of the lymph nodes, weight loss, or fever.
- **heart failure (rare).** Symptoms of heart failure can include shortness of breath or swelling of your feet.
- **signs of immune system disorders called:**
 - **lupus (rare).** Symptoms can include joint pain or a rash on cheeks or arms that is sensitive to the sun.
 - **sarcoidosis (rare).** Symptoms can include a persistent cough, being short of breath, chest pain, fever, swelling of your lymph nodes, weight loss, skin rashes, and blurred vision.

- **swelling of small blood vessels (vasculitis) (rare).** Symptoms can include fever, headache, weight loss, night sweats, rash, and nerve problems such as numbness and tingling.
- **skin cancer (uncommon).** Symptoms of skin cancer can include changes in the appearance of your skin or growths on your skin.
- **blood disease (common).** Symptoms of blood disease can include a fever that does not go away, bruising or bleeding very easily or looking very pale.
- **blood cancer (leukaemia) (rare).** Symptoms of leukaemia can include fever, feeling tired, frequent infections, easy bruising, and night sweats.

Tell your doctor straight away if you notice any of the above symptoms.

The following additional side effects have been observed with Simponi:

Very common side effects (may affect more than 1 in 10 people):

- Upper respiratory tract infections, sore throat or hoarseness, runny nose

Common side effects (may affect up to 1 in 10 people):

- Abnormal liver tests (increased liver enzymes) found during blood tests done by your doctor
- Feeling dizzy
- Headache
- Feeling numb or having a tingling feeling
- Superficial fungal infections
- Abscess
- Bacterial infections (such as cellulitis)
- Low red blood cell counts
- Low white blood cell counts
- Positive blood lupus test
- Allergic reactions
- Indigestion
- Stomach pain
- Feeling sick (nausea)
- Flu
- Bronchitis
- Sinus infection
- Cold sores
- High blood pressure
- Fever
- Asthma, shortness of breath, wheezing

- Stomach and bowel disorders which include inflammation of the stomach lining and colon which may cause fever
- Pain and ulcers in the mouth
- Injection site reactions (including redness, hardness, pain, bruising, itching, tingling and irritation)
- Hair loss
- Rash and itching of the skin
- Difficulty sleeping
- Depression
- Feeling weak
- Bone fractures
- Chest discomfort

Uncommon side effects (may affect up to 1 in 100 people):

- Kidney infection
- Cancers, including skin cancer and non-cancerous growths or lumps, including skin moles
- Skin blisters
- Severe infection throughout the body (sepsis), sometimes including low blood pressure (septic shock)
- Psoriasis (including on the palms of your hand and/or the soles of your feet and/or in the form of skin blisters)
- Low platelet count
- Combined low platelet, red, and white blood cell count
- Thyroid disorders
- Increase in blood sugar levels
- Increase in blood cholesterol levels
- Balance disorders
- Vision disturbances
- Inflamed eye (conjunctivitis)
- Eye allergy
- Sensation of heart beating irregularly
- Narrowing of the blood vessels in the heart
- Blood clots
- Flushing
- Constipation
- Chronic inflammatory condition of the lungs
- Acid reflux

- Gall stones
- Liver disorders
- Breast disorders
- Menstrual disorders

Rare side effects (may affect up to 1 in 1,000 people):

- Failure of the bone marrow to produce blood cells
- Severely decreased number of white blood cells
- Infection of the joints or the tissue around them
- Impaired healing
- Inflammation of blood vessels in internal organs
- Leukaemia
- Melanoma (a type of skin cancer)
- Merkel cell carcinoma (a type of skin cancer)
- Lichenoid reactions (itchy reddish-purple skin rash and/or threadlike white-grey lines on mucous membranes)
- Scaly, peeling skin
- Immune disorders that could affect the lungs, skin and lymph nodes (most commonly presenting as sarcoidosis)
- Pain and discolouration in the fingers or toes
- Taste disturbances
- Bladder disorders
- Kidney disorders
- Inflammation of the blood vessels in your skin which results in rash

Side effects of which the frequency is not known:

- A rare blood cancer affecting mostly young people (hepatosplenic T-cell lymphoma)
- Kaposi's sarcoma, a rare cancer related to infection with human herpes virus 8. Kaposi's sarcoma most commonly appears as purple lesions on the skin
- Worsening of a condition called dermatomyositis (seen as a skin rash accompanying muscle weakness)

Reporting of side effects

If you get any side effects, talk to your doctor, pharmacist or nurse. This includes any possible side effects not listed in this leaflet. You can also report side effects directly via the [national reporting system](#). By reporting side effects you can help provide more information on the safety of this medicine.

5. How to store Simponi

- Keep this medicine out of the sight and reach of children.
- Do not use this medicine after the expiry date which is stated on the label and the carton after "EXP". The expiry date refers to the last day of that month.
- Store in a refrigerator (2°C-8°C). Do not freeze.
- Keep the pre-filled syringe in the outer carton in order to protect it from light.
- This medicine can also be stored out of the refrigerator at temperatures up to a maximum of 25°C for a single period of up to 30 days, but not beyond the original expiry date printed on the carton. Write the new expiry date on the carton including day/month/year (no more than 30 days after the medicine is removed from the refrigerator). Do not return this medicine to refrigerator if it has reached room temperature. Discard this medicine if not used by the new expiry date or the expiry date printed on the carton, whichever is earlier.
- Do not use this medicine if you notice that the liquid is not a clear to light yellow colour, cloudy, or contains foreign particles.
- Do not throw away any medicines via wastewater or household waste. Ask your doctor or pharmacist how to throw away medicines you no longer use. These measures will help to protect the environment.

6. Contents of the pack and other information

What Simponi contains

The active substance is golimumab. One 0.5 mL pre-filled syringe contains 50 mg of golimumab.

The other ingredients are sorbitol (E420), histidine, histidine hydrochloride monohydrate, polysorbate 80 and water for injections. For more information on sorbitol (E420), see Section 2.

What Simponi looks like and contents of the pack

Simponi is supplied as solution for injection in a single-use pre-filled syringe Simponi is available in packs containing 1 pre-filled syringe and multipacks containing 3 (3 packs of 1) pre-filled syringes. Not all pack sizes may be marketed.

The solution is clear to slightly opalescent (having a pearl-like shine), colourless to light yellow and may contain a few small translucent or white particles of protein. Do not use Simponi if the solution is discoloured, cloudy or you can see foreign particles in it.

For any information about this medicine, please contact the local representative of the Marketing Authorisation Holder.

This leaflet was last revised in

08-Mar-2024 (EUPIL version 22-Jun-2023)

MARKETING AUTHORISATION NUMBER(S) AND DATE OF AUTHORIZATION

Product Name	License number	Manufactured by	Date of Authorization
SIMPONI SOLUTION FOR INJECTION	1C 1/57 (NB)	Baxter Pharmaceutical Solution LLC, Indiana, USA	24-Jan-2014

Imported by

Janssen-Cilag Ltd., Bangkok, Thailand

To report Suspected Adverse Reactions, please contact us at aepqjacth@its.jnj.com

For any product information, please contact us at medinfosea@its.jnj.com

Please see full prescribing information at <https://ndi.fda.moph.go.th>

INSTRUCTIONS FOR USE

If you would like to self inject Simponi, you must be trained by a healthcare professional to prepare an injection and give it to yourself. If you have not been trained, please contact your doctor, nurse or pharmacist to schedule a training session.

Approval on 8-Mar-2024

In these instructions:

1. Preparing for use of the pre-filled syringe
2. Choosing and preparing the injection site
3. Injecting the medicine
4. After the injection

The diagram below (see figure 1) shows what the pre-filled syringe looks like.

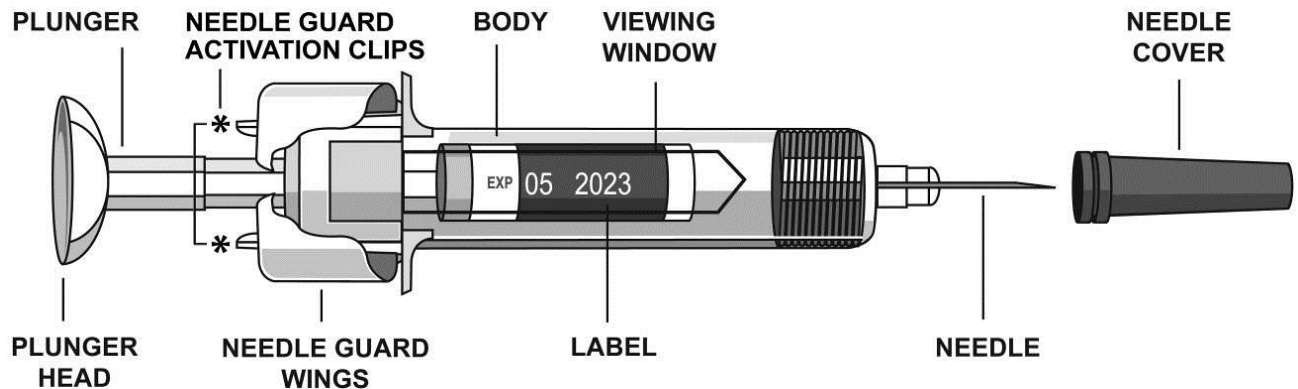

Figure 1

1. Preparing for use of the pre-filled syringe

Hold the pre-filled syringe by the body of the pre-filled syringe

- Do not hold by the plunger head, plunger, needle guard wings, or needle cover.
- Do not pull back on the plunger at any time.
- Do not shake the pre-filled syringe at any time.
- Do not remove the needle cover from the pre-filled syringe until instructed to do so.
- Do not touch the needle guard activation clips (as indicated by asterisks * in figure 1) to prevent prematurely covering the needle with the needle guard.

Check the number of pre-filled syringes

Check the pre-filled syringes to make sure

- the number of pre-filled syringes and strength is correct
 - If your dose is 50 mg, you will get one 50 mg pre-filled syringe
 - If your dose is 100 mg, you will get two 50 mg pre-filled syringes and you will need to give yourself two injections. Choose two different sites for these injections (e.g. one injection in the right thigh and the other injection in the left thigh), and give the injections one right after the other.
 - If your dose is 200 mg, you will get four 50 mg pre-filled syringes and you will need to give yourself four injections. Choose different sites for these injections and give the injections one right after the other.

Check expiry date (see figure 2)

- Check the expiration date printed or written on the carton.
- Check the expiration date (as indicated by "EXP") on the label by looking through the viewing window located within the body of the pre-filled syringe.
- If you cannot see the expiration date through the viewing window, hold the pre-filled syringe by its body and rotate the needle cover to line up the expiration date to the viewing window.

Do not use the pre-filled syringe if the expiration date has passed. The printed expiration date refers to the last day of the month. Please contact your doctor or pharmacist for assistance.

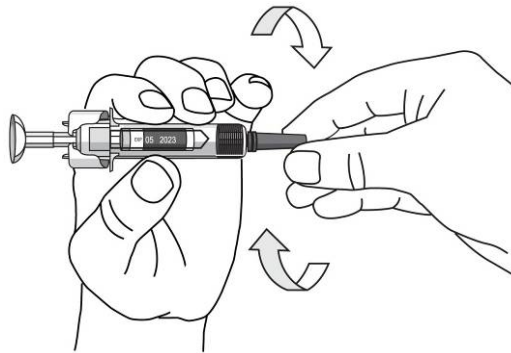

Figure 2

Wait 30 minutes to allow pre-filled syringe to reach room temperature

- To ensure proper injection, allow the pre-filled syringe to sit at room temperature outside the box for 30 minutes, out of the reach of children.

Do not warm the pre-filled syringe in any other way (for example, do not warm it in a microwave or in hot water).

Do not remove the pre-filled syringe's needle cover while allowing it to reach room temperature.

Get the rest of your equipment ready

While you are waiting you can get the rest of your equipment ready, including an alcohol swab, a cotton ball or gauze and a sharps container.

Check the liquid in the pre-filled syringe

- Hold the pre-filled syringe by its body with the covered needle pointing downward.
- Look at the liquid through the viewing window of the pre-filled syringe and make sure that it is clear to slightly opalescent (having a pearl-like shine) and colourless to light yellow. The solution can be used if it contains a few small translucent or white particles of protein.

- If you cannot see the liquid through the viewing window, hold the pre-filled syringe by its body and rotate the needle cover to line up the liquid to the viewing window (see figure 2).

Do not use the pre-filled syringe if the liquid is the wrong colour, cloudy, or contains larger particles. If this happens, talk to your doctor or pharmacist.

2. Choosing and preparing the injection site (see figure 3)

- You usually inject the medicine into the front of the middle thighs.
- You can also use the lower stomach (abdomen) below the belly button, except for approximately the 5 cm area directly underneath the belly button.
- Do not inject into areas where the skin is tender, bruised, red, scaly, hard or has scars or stretch marks.
- If multiple injections are required for a single administration, the injections should be administered at different sites on the body.

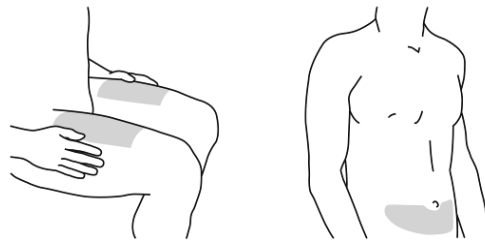

Figure 3

Injection site selection for caregivers (see figure 4)

- If a caregiver is giving you the injection, they can also use the outer area of the upper arms.
- Again, all sites mentioned can be used regardless of your body type or size.

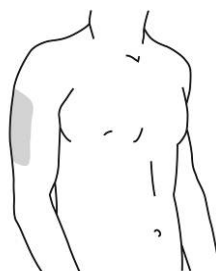

Figure 4

Preparing injection site

- Wash your hands thoroughly with soap and warm water.
- Wipe the injection site with an alcohol swab.
- Allow the skin to dry before injecting. Do not fan or blow on the clean area.

Do not touch this area again before giving the injection.

3. Injecting the medicine

The needle cover should not be removed until you are ready to inject the medicine. The medicine should be injected within 5 minutes after the needle cover has been removed.

Do not touch the plunger during needle cover removal.

Remove the needle cover (see figure 5)

- When you are ready to inject, hold the body of the pre-filled syringe with one hand.
- Pull the needle cover straight off and throw it away after your injection. Do not touch the plunger while you do this.
- You may notice an air bubble in the pre-filled syringe or a drop of liquid at the end of the needle. These are both normal and do not need to be removed.
- Inject the dose promptly after removing the needle cover.

Do not touch the needle or allow it to touch any surface.

Do not use the pre-filled syringe if it is dropped without the needle cover in place. If this happens, please contact your doctor or pharmacist.

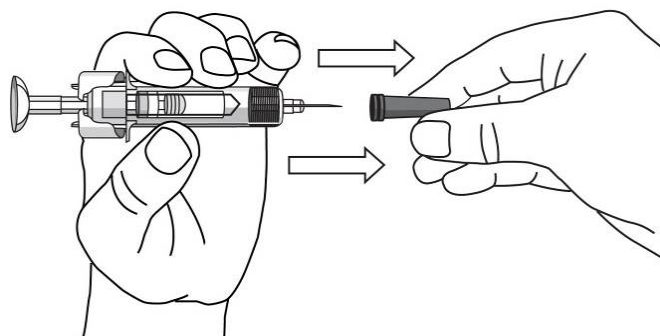

Figure 5

Position the pre-filled syringe to inject

- Hold the body of the pre-filled syringe with one hand between the middle and index fingers and place the thumb on top of the plunger head and use the other hand to gently pinch the area of skin that you previously cleaned. Hold firmly.

Do not pull back on the plunger at any time.

Inject the medicine

- Place the needle at approximately a 45-degree angle to the pinched skin. In a single and swift motion, insert the needle through the skin as far as it will go (see figure 6).

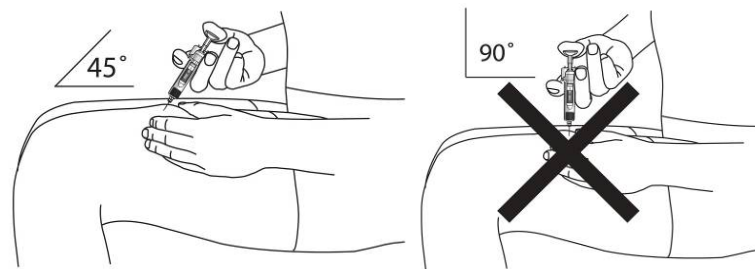

Figure 6

- Inject all of the medicine by pushing in the plunger until the plunger head is completely between the needle guard wings (see figure 7).

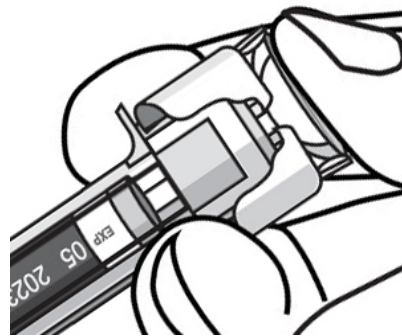

Figure 7

- When the plunger is pushed as far as it will go, continue to keep the pressure on the plunger head, take out the needle and let go of the skin (see figure 8).

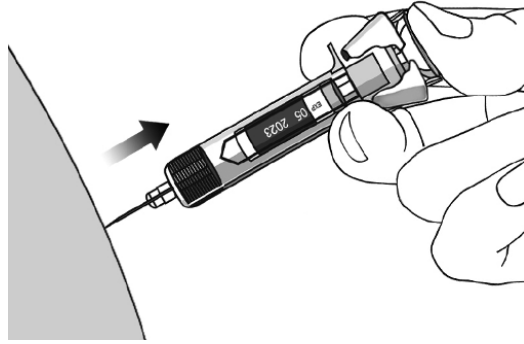

Figure 8

- Slowly take your thumb off the plunger head to allow the empty pre-filled syringe to move up until the entire needle is covered by the needle guard, as shown by the figure 9:

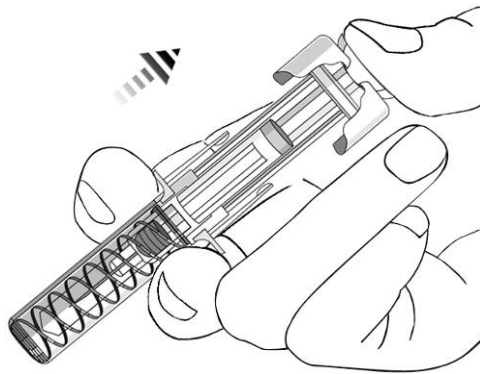

Figure 9

4. After the injection

Use a cotton ball or gauze

- There may be a small amount of blood or liquid at the injection site. This is normal.
- You can press a cotton ball or gauze over the injection site and hold for 10 seconds.
- You may cover the injection site with a small adhesive bandage, if necessary.

Do not rub your skin.

Throw the pre-filled syringe away (see figure 10)

- Place your pre-filled syringe in a sharps container straight away. Make sure you dispose of the bin as instructed by your doctor or nurse.

Do not attempt to recap the needle.

Do not ever re-use a pre-filled syringe, for your safety and health and for the safety of others.

If you feel that something has gone wrong with the injection or if you are not sure, talk to your doctor or pharmacist.



Figure 10

Package Leaflet: Information for the user

SIMPONI® SOLUTION FOR INJECTION

Simponi 100 mg solution for injection in pre-filled pen golimumab

Read all of this leaflet carefully before you start using this medicine because it contains important information for you.

- Keep this leaflet. You may need to read it again.
- If you have any further questions, ask your doctor, pharmacist or nurse.
- This medicine has been prescribed for you only. Do not pass it on to others. It may harm them, even if their signs of illness are the same as yours.
- If you get any side effects, talk to your doctor, pharmacist or nurse. This includes any possible side effects not listed in this leaflet. See section 4.

Your doctor will also give you a Patient Reminder Card, which contains important safety information you need to be aware of before and during your treatment with Simponi.

What is in this leaflet

1. What Simponi is and what it is used for
2. What you need to know before you use Simponi
3. How to use Simponi
4. Possible side effects
5. How to store Simponi
6. Contents of the pack and other information

1. What Simponi is and what it is used for

Simponi contains the active substance called golimumab.

Simponi belongs to a group of medicines called 'TNF blockers'. It is used **in adults** for the treatment of the following inflammatory diseases:

- Rheumatoid arthritis
- Psoriatic arthritis

- Axial spondyloarthritis, including ankylosing spondylitis and non-radiographic axial spondyloarthritis
- Ulcerative colitis

Simponi works by blocking the action of a protein called 'tumour necrosis factor alpha' (TNF- α). This protein is involved in inflammatory processes of the body, and blocking it can reduce the inflammation in your body.

Rheumatoid arthritis

Rheumatoid arthritis is an inflammatory disease of the joints. If you have active rheumatoid arthritis

you will first be given other medicines. If you do not respond well enough to these medicines, you may be given Simponi which you will take in combination with another medicine called methotrexate to:

- Reduce the signs and symptoms of your disease.
- Slow down the damage to your bones and joints.
- Improve your physical function.

Psoriatic arthritis

Psoriatic arthritis is an inflammatory disease of the joints, usually accompanied by psoriasis, an inflammatory disease of the skin. If you have active psoriatic arthritis you will first be given other medicines. If you do not respond well enough to these medicines, you may be given Simponi to:

- Reduce the signs and symptoms of your disease.
- Slow down the damage to your bones and joints.
- Improve your physical function.

Ankylosing spondylitis and non-radiographic axial spondyloarthritis

Ankylosing spondylitis and non-radiographic axial spondyloarthritis are inflammatory diseases of the spine. If you have ankylosing spondylitis or non-radiographic axial spondyloarthritis, you will first be given other medicines. If you do not respond well enough to these medicines, you may be given Simponi to:

- Reduce the signs and symptoms of your disease.
- Improve your physical function.

Ulcerative colitis

Ulcerative colitis is an inflammatory disease of the bowel. If you have ulcerative colitis you will first be given other medicines. If you do not respond well enough to these medicines, you will be given Simponi to treat your disease.

2. What you need to know before you use Simponi

Do not use Simponi:

- If you are allergic (hypersensitive) to golimumab or any of the other ingredients of this medicine (listed in Section 6).
- If you have tuberculosis (TB) or any other severe infection.
- If you have moderate or severe heart failure.

If you are not sure if any of the above applies to you, talk to your doctor, pharmacist or nurse before using Simponi.

Warnings and precautions

Talk to your doctor, pharmacist or nurse before using Simponi.

Infections

Tell your doctor straight away if you already have or get any symptoms of infection, during or after your treatment with Simponi. Symptoms of infection include fever, cough, shortness of breath, flu-like symptoms, diarrhoea, wounds, dental problems or a burning feeling when urinating.

- You may get infections more easily while using Simponi.
- Infections may progress more rapidly and may be more severe. In addition, some previous infections may reappear.

Tuberculosis (TB)

Tell your doctor straight away if symptoms of TB appear during or after your treatment. Symptoms of TB include persistent cough, weight loss, tiredness, fever or night sweats.

- Cases of TB have been reported in patients treated with Simponi, in rare occasions even in patients who have been treated with medicines for TB. Your doctor will test you to see if you have TB. Your doctor will record these tests on your Patient Reminder Card.
- It is very important that you tell your doctor if you have ever had TB, or if you have been in close contact with someone who has had or has TB.
- If your doctor feels that you are at risk of TB, you may be treated with medicines for TB before you begin using Simponi.

Hepatitis B virus (HBV)

- Tell your doctor if you are a carrier or if you have or have had HBV before you are given Simponi.
- Tell your doctor if you think you might be at risk of contracting HBV
- Your doctor should test you for HBV

- Treatment with TNF blockers such as Simponi may result in reactivation of HBV in patients who carry this virus, which can be life-threatening in some cases.

Invasive fungal infections

If you have lived in or travelled to an area where infections caused by specific type of fungi that can affect the lungs or other parts of the body (called histoplasmosis, coccidioidomycosis, or blastomycosis), are common, tell your doctor straight away. Ask your doctor if you don't know if these fungal infections are common in the area in which you have lived or travelled.

Cancer and lymphoma

Tell your doctor if you have ever been diagnosed with lymphoma (a type of blood cancer) or any other cancer before you use Simponi.

- If you use Simponi or other TNF blockers, your risk for developing lymphoma or another cancer may increase.
- Patients with severe rheumatoid arthritis and other inflammatory diseases, who have had the disease for a long time, may be at higher than average risk of developing lymphoma.
- There have been cases of cancers, including unusual types, in children and teenage patients taking TNF-blocking agents, which sometimes resulted in death.
- On rare occasions, a specific and severe type of lymphoma called hepatosplenic T-cell lymphoma has been observed in patients taking other TNF-blockers. Most of these patients were adolescent or young adult males. This type of cancer has usually resulted in death. Almost all of these patients had also received medicines known as azathioprine or 6-mercaptopurine. Tell your doctor if you are taking azathioprine or 6-mercaptopurine with Simponi.
- Patients with severe persistent asthma, chronic obstructive pulmonary disease (COPD), or are heavy smokers may be at increased risk for cancer with Simponi treatment. If you have severe persistent asthma, COPD or are a heavy smoker, you should discuss with your doctor whether treatment with a TNF blocker is appropriate for you.
- Some patients treated with golimumab have developed certain kinds of skin cancer. If any changes in the appearance of the skin or growths on the skin occur during or after therapy, tell your doctor.

Heart failure

Tell your doctor straight away if you get new or worsening symptoms of heart failure. Symptoms of heart failure include shortness of breath or swelling of your feet.

- New and worsening congestive heart failure has been reported with TNF blockers, including Simponi. Some of these patients died.
- If you have mild heart failure and you are being treated with Simponi, you must be closely monitored by your doctor.

Nervous system disease

Tell your doctor straight away if you have ever been diagnosed with or develop symptoms of a demyelinating disease such as multiple sclerosis. Symptoms may include changes in your vision, weakness in your arms or legs or numbness or tingling in any part of your body. Your doctor will decide if you should receive Simponi.

Operations or dental procedures

- Talk to your doctor if you are going to have any operations or dental procedures.
- Tell your surgeon or dentist performing the procedure that you are having treatment with Simponi by showing them your Patient Reminder Card.

Autoimmune disease

Tell your doctor if you develop symptoms of a disease called lupus. Symptoms include persistent rash, fever, joint pain and tiredness.

- On rare occasions, people treated with TNF blockers have developed lupus.

Blood disease

In some patients the body may fail to produce enough of the blood cells that help your body fight infections or help you to stop bleeding. If you develop a fever that does not go away, bruise or bleed very easily or look very pale, call your doctor right away. Your doctor may decide to stop treatment.

If you are not sure if any of the above applies to you, talk to your doctor or pharmacist before using Simponi.

Vaccinations

Talk to your doctor if you have had, or are due to have a vaccine.

- You should not receive certain (live) vaccines while using Simponi.
- Certain vaccinations may cause infections. If you received Simponi while you were pregnant, your baby may be at higher risk for getting such an infection for up to approximately six months after the last dose you received during pregnancy. It is important that you tell your baby's doctors and other health care professionals about your Simponi use so they can decide when your baby should receive any vaccine.

Therapeutic infectious agents

Talk to your doctor if you have recently received or are scheduled to receive treatment with a therapeutic infectious agent (such as BCG instillation used for the treatment of cancer).

Allergic reactions

Tell your doctor straight away if you develop symptoms of an allergic reaction after your treatment with Simponi. Symptoms of an allergic reaction may include swelling of the face,

lips, mouth or throat which may cause difficulty in swallowing or breathing, skin rash, hives, swelling of the hands, feet or ankles.

- Some of these reactions may be serious or, rarely, life-threatening.
- Some of these reactions occurred after the first administration of Simponi.

Children and adolescents

Simponi 100 mg is not recommended for children and adolescents (younger than 18 years).

Other medicines and Simponi

- Tell your doctor or pharmacist if you are using, have recently used or might use any other medicines, including any other medicines to treat rheumatoid arthritis, psoriatic arthritis, ankylosing spondylitis, non-radiographic axial spondyloarthritis, or ulcerative colitis.
- You should not take Simponi with medicines containing the active substance anakinra or abatacept. These medicines are used for the treatment of rheumatic diseases.
- Tell your doctor or pharmacist if you are taking any other medicines that affect your immune system.
- You should not receive certain (live) vaccines while using Simponi.

If you are not sure if any of the above applies to you, talk to your doctor or pharmacist before using Simponi.

Pregnancy and breast-feeding

Talk to your doctor before using Simponi if:

- You are pregnant or are planning to become pregnant while using Simponi. There is limited information about the effects of this medicine in pregnant women. If you are being treated with Simponi, you must avoid becoming pregnant by using adequate contraception during your treatment and for at least 6 months after the last Simponi injection. Simponi should only be used during pregnancy if it is clearly necessary for you.
- Before starting breast-feeding, your last treatment with Simponi must be at least 6 months ago. You must stop breast-feeding if you are to be given Simponi.
- If you received Simponi during your pregnancy, your baby may have a higher risk for getting an infection. It is important that you tell your baby's doctors and other health care professionals about your Simponi use before the baby receives any vaccine (for more information see section on vaccination).

If you are pregnant or breast-feeding, think you may be pregnant or are planning to have a baby, ask your doctor or pharmacist for advice before taking this medicine.

Driving and using machines

Simponi has minor influence on your ability to drive and use tools or machines. Dizziness may however occur after you take Simponi. If this happens, do not drive or use any tools or machines.

Simponi contains latex and sorbitol

Latex sensitivity

A part of the pre-filled pen, the needle cover, contains latex. Because latex may cause severe allergic reactions, talk to your doctor before using Simponi if you or your carer are allergic to latex.

Sorbitol intolerance

This medicine contains 41 mg sorbitol (E420) in each pre-filled pen.

3. How to use Simponi

Always use this medicine exactly as your doctor or pharmacist has told you. You should check with your doctor or pharmacist if you are not sure.

How much Simponi is given

Rheumatoid arthritis, psoriatic arthritis, and axial spondyloarthritis, including ankylosing spondylitis and non-radiographic axial spondyloarthritis:

- The recommended dose is 50 mg given once a month, on the same date each month.
- Talk to your doctor before taking your fourth dose. Your doctor will determine if you should continue Simponi treatment.
 - If you weigh more than 100 kg, the dose might be increased to 100 mg (the content of 1 pre-filled pen) given once a month, on the same date each month.

Ulcerative colitis

- The table below shows how you will usually use this medicine.

Initial treatment	A starting dose of 200 mg (the contents of 2 pre-filled pens) followed by 100 mg (the contents of 1 pre-filled pen) 2 weeks later.
Maintenance treatment	<ul style="list-style-type: none"> In patients weighing less than 80 kg, 50 mg (the 50 mg pre-filled pen or pre-filled syringe must be used to administer this dose) 4 weeks after your last treatment, then every 4 weeks thereafter. Your doctor may decide to prescribe 100 mg (the contents of 1 pre-filled pen), depending on how well Simponi works for you. In patients weighing 80 kg or more, 100 mg (the contents of 1 pre-filled pen) 4 weeks after your last treatment, then every 4 weeks thereafter.

How Simponi is given

- Simponi is given by injection under the skin (subcutaneously).
- At the start, your doctor or nurse may inject Simponi. However, you and your doctor may decide that you may inject Simponi yourself. In this case you will get training on how to inject Simponi yourself.

Talk to your doctor if you have any questions about giving yourself an injection. You will find detailed "Instructions for Use" at the end of this leaflet.

If you use more Simponi than you should

If you have used or been given too much Simponi (either by injecting too much on a single occasion, or by using it too often), talk to your doctor or pharmacist straight away. Always take the outer carton and this leaflet with you, even if it is empty.

If you forget to use Simponi

If you forget to use Simponi on your planned date, inject the forgotten dose as soon as you remember.

Do not use a double dose to make up for a forgotten dose.

When to inject your next dose:

- If you are less than 2 weeks late, inject the forgotten dose as soon as you remember and stay on your original schedule.
- If you are more than 2 weeks late, inject the forgotten dose as soon as you remember and talk to your doctor or pharmacist to ask when you need to take the next dose.

If you are not sure what to do, talk to your doctor or pharmacist.

If you stop using Simponi

If you are considering stopping Simponi, talk to your doctor or pharmacist first.

If you have any further questions on the use of this medicine, ask your doctor, pharmacist or nurse.

4. Possible side effects

Like all medicines, this medicine can cause side effects, although not everybody gets them. Some patients may experience serious side effects and may require treatment. The risk of certain side effects is greater with the 100 mg dose compared with the 50 mg dose. Side effects may appear up to several months after the last injection.

Tell your doctor straight away if you notice any of the following serious side effects of Simponi which include:

- **allergic reactions which may be serious, or rarely, life-threatening (rare).** Symptoms of an allergic reaction may include swelling of the face, lips, mouth or throat which may cause difficulty in swallowing or breathing, skin rash, hives, swelling of the hands, feet or ankles. Some of these reactions occurred after the first administration of Simponi.
- **serious infections (including TB, bacterial infections including serious blood infections and pneumonia, severe fungal infections and other opportunistic infections) (common).** Symptoms of an infection can include fever, tiredness, (persistent) cough, shortness of breath, flu-like symptoms, weight loss, night sweats, diarrhoea, wounds, dental problems and a burning feeling when urinating.
- **reactivation of hepatitis B virus if you are a carrier or have had hepatitis B before (rare).** Symptoms can include yellowing of the skin and eyes, dark brown-coloured urine, right-sided abdominal pain, fever, feeling sick, being sick, and feeling very tired.
- **nervous system disease such as multiple sclerosis (rare).** Symptoms of nervous system disease can include changes in your vision, weakness in your arms or legs, numbness or tingling in any part of your body.
- **cancer of the lymph nodes (lymphoma) (rare).** Symptoms of lymphoma can include swelling of the lymph nodes, weight loss, or fever.
- **heart failure (rare).** Symptoms of heart failure can include shortness of breath or swelling of your feet.
- **signs of immune system disorders called:**
 - **lupus (rare).** Symptoms can include joint pain or a rash on cheeks or arms that is sensitive to the sun.
 - **sarcoidosis (rare).** Symptoms can include a persistent cough, being short of breath, chest pain, fever, swelling of your lymph nodes, weight loss, skin rashes, and blurred vision.
- **swelling of small blood vessels (vasculitis) (rare).** Symptoms can include fever, headache, weight loss, night sweats, rash, and nerve problems such as numbness and tingling.
- **skin cancer (uncommon).** Symptoms of skin cancer can include changes in the appearance of your skin or growths on your skin.

- **blood disease (common).** Symptoms of blood disease can include a fever that does not go away, bruising or bleeding very easily or looking very pale.
- **blood cancer (leukaemia) (rare).** Symptoms of leukaemia can include fever, feeling tired, frequent infections, easy bruising, and night sweats.

Tell your doctor straight away if you notice any of the above symptoms.

The following additional side effects have been observed with Simponi:

Very common side effects (may affect more than 1 in 10 people):

- Upper respiratory tract infections, sore throat or hoarseness, runny nose

Common side effects (may affect up to 1 in 10 people):

- Abnormal liver tests (increased liver enzymes) found during blood tests done by your doctor
- Feeling dizzy
- Headache
- Feeling numb or having a tingling feeling
- Superficial fungal infections
- Abscess
- Bacterial infections (such as cellulitis)
- Low red blood cell counts
- Low white blood cell counts
- Positive blood lupus test
- Allergic reactions
- Indigestion
- Stomach pain
- Feeling sick (nausea)
- Flu
- Bronchitis
- Sinus infection
- Cold sores
- High blood pressure
- Fever
- Asthma, shortness of breath, wheezing
- Stomach and bowel disorders which include inflammation of the stomach lining and colon which may cause fever
- Pain and ulcers in the mouth
- Injection site reactions (including redness, hardness, pain, bruising, itching, tingling and irritation)
- Hair loss

- Rash and itching of the skin
- Difficulty sleeping
- Depression
- Feeling weak
- Bone fractures
- Chest discomfort

Uncommon side effects (may affect up to 1 in 100 people):

- Kidney infection
- Cancers, including skin cancer and non-cancerous growths or lumps, including skin moles
- Skin blisters
- Severe infection throughout the body (sepsis), sometimes including low blood pressure (septic shock)
- Psoriasis (including on the palms of your hand and/or the soles of your feet and/or in the form of skin blisters)
- Low platelet count
- Combined low platelet, red, and white blood cell count
- Thyroid disorders
- Increase in blood sugar levels
- Increase in blood cholesterol levels
- Balance disorders
- Vision disturbances
- Inflamed eye (conjunctivitis)
- Eye allergy
- Sensation of heart beating irregularly
- Narrowing of the blood vessels in the heart
- Blood clots
- Flushing
- Constipation
- Chronic inflammatory condition of the lungs
- Acid reflux
- Gall stones
- Liver disorders
- Breast disorders
- Menstrual disorders

Rare side effects (may affect up to 1 in 1,000 people):

- Failure of the bone marrow to produce blood cells
- Severely decreased number of white blood cells
- Infection of the joints or the tissue around them
- Impaired healing
- Inflammation of blood vessels in internal organs
- Leukaemia
- Melanoma (a type of skin cancer)
- Merkel cell carcinoma (a type of skin cancer)
- Lichenoid reactions (itchy reddish-purple skin rash and/or threadlike white-grey lines on mucous membranes)
- Scaly, peeling skin
- Immune disorders that could affect the lungs, skin and lymph nodes (most commonly presenting as sarcoidosis)
- Pain and discolouration in the fingers or toes
- Taste disturbances
- Bladder disorders
- Kidney disorders
- Inflammation of the blood vessels in your skin which results in rash

Side effects of which the frequency is not known:

- A rare blood cancer affecting mostly young people (hepatosplenic T-cell lymphoma)
- Kaposi's sarcoma, a rare cancer related to infection with human herpes virus 8. Kaposi's sarcoma most commonly appears as purple lesions on the skin
- Worsening of a condition called dermatomyositis (seen as a skin rash accompanying muscle weakness)

Reporting of side effects

If you get any side effects, talk to your doctor, pharmacist or nurse. This includes any possible side effects not listed in this leaflet. You can also report side effects directly via the national reporting system. By reporting side effects you can help provide more information on the safety of this medicine.

5. How to store Simponi

- Keep this medicine out of the sight and reach of children.
- Do not use this medicine after the expiry date which is stated on the label and the carton after "EXP". The expiry date refers to the last day of that month.
- Store in a refrigerator (2°C-8°C). Do not freeze.

- Keep the pre-filled pen in the outer carton in order to protect it from light.
- This medicine can also be stored out of the refrigerator at temperatures up to a maximum of 25°C for a single period of up to 30 days, but not beyond the original expiry date printed on the carton. Write the new expiry date on the carton including day/month/year (no more than 30 days after the medicine is removed from the refrigerator). Do not return this medicine to refrigerator if it has reached room temperature. Discard this medicine if not used by the new expiry date or the expiry date printed on the carton, whichever is earlier.
- Do not use this medicine if you notice that the liquid is not a clear to light yellow colour, cloudy, or contains foreign particles.
- Do not throw away any medicines via wastewater or household waste. Ask your doctor or pharmacist how to throw away medicines you no longer use. These measures will help to protect the environment.

6. Contents of the pack and other information

What Simponi contains

The active substance is golimumab. One 1 mL pre-filled pen contains 100 mg of golimumab.

The other ingredients are sorbitol (E420), histidine, histidine hydrochloride monohydrate, polysorbate 80 and water for injections. For more information on sorbitol (E420), see Section 2.

What Simponi looks like and contents of the pack

Simponi is supplied as solution for injection in a single-use pre-filled pen. Simponi is available in packs containing 1 pre-filled pen and multipacks containing 3 (3 packs of 1) pre-filled pens. Not all pack sizes may be marketed.

The solution is clear to slightly opalescent (having a pearl-like shine), colourless to light yellow and may contain a few small translucent or white particles of protein. Do not use Simponi if the solution is discoloured, cloudy or you can see foreign particles in it.

For any information about this medicine, please contact the local representative of the Marketing Authorisation Holder.

This leaflet was last revised in

08-Mar-2024 (EUPIL version 22-Jun-2023)

MARKETING AUTHORISATION NUMBER(S) AND DATE OF AUTHORIZATION

Product Name	License number	Manufactured by	Date of Authorization
SIMPONI SOLUTION FOR INJECTION	1C 1/57 (NB)	Baxter Pharmaceutical Solution LLC, Indiana, USA	24-Jan-2014

Imported by

Janssen-Cilag Ltd., Bangkok, Thailand

To report Suspected Adverse Reactions, please contact us at aepqcjacth@its.jnj.com

For any product information, please contact us at medinfosea@its.jnj.com

Please see full prescribing information at <https://ndi.fda.moph.go.th>

INSTRUCTIONS FOR USE

If you would like to self inject Simponi, you must be trained by a healthcare professional to prepare an injection and give it to yourself. If you have not been trained, please contact your doctor, nurse or pharmacist to schedule a training session.

In these instructions:

1. Preparing for use of the pre-filled pen
2. Choosing and preparing the injection site
3. Injecting the medicine
4. After the injection

The diagram below (see figure 1) shows what the “SmartJect” pre-filled pen looks like.

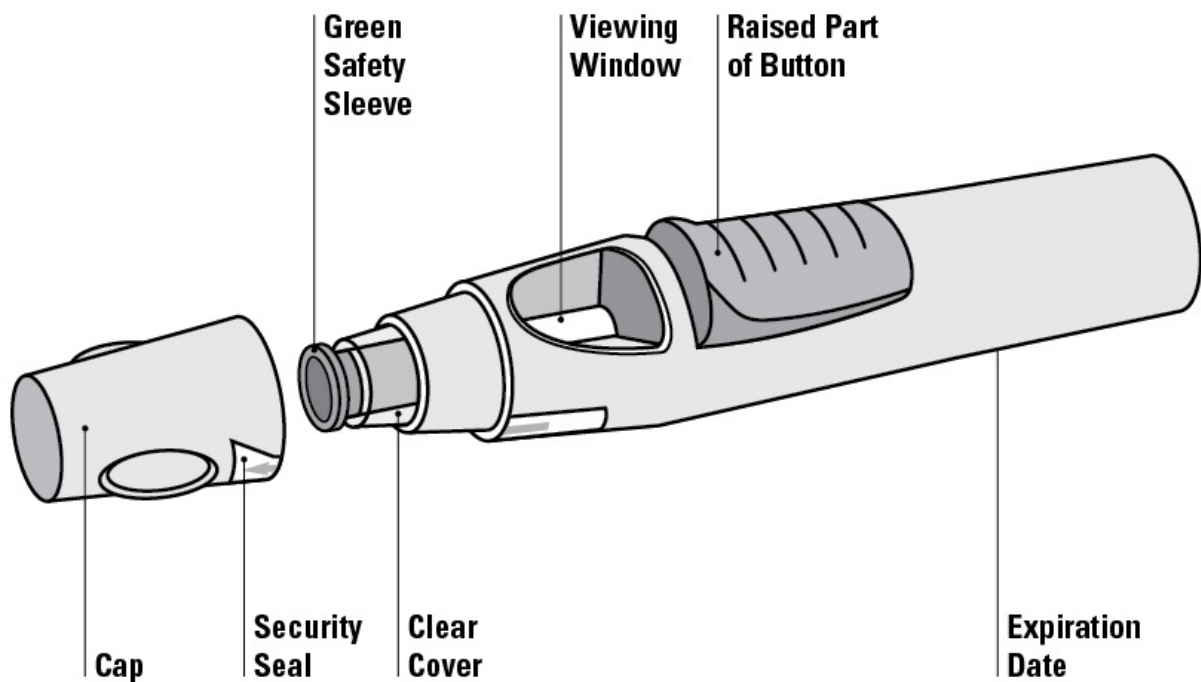

Figure 1

1. Preparing for use of the pre-filled pen

- Do not shake the pre-filled pen at any time.
- Do not remove the cap from the pre-filled pen until immediately before the injection.
- Do not put the cap of the pre-filled pen back on if removed to avoid bending the needle.

Check the number of pre-filled pens

Check the pre-filled pens to make sure

- the number of pre-filled pens and strength is correct
 - If your dose is 100 mg, you will get one 100 mg pre-filled pen
 - If your dose is 200 mg, you will get two 100 mg pre-filled pens and you will need to give yourself two injections. Choose different sites for these injections and give the injections one right after the other.

Check expiry date

- Check the expiration date printed or written on the carton.
- Check the expiration date (as indicated as “EXP”) on the pre-filled pen.
- Do not use the pre-filled pen if the expiration date has passed. The printed expiration date refers to the last day of the month. Please contact your doctor or pharmacist for assistance.

Check security seal

- Check the security seal around the cap of the pre-filled pen.
- Do not use the pre-filled pen if the seal is broken. Please contact your doctor or pharmacist.

Wait 30 minutes to allow pre-filled pen to reach room temperature

- To ensure proper injection, allow the pre-filled pen to sit at room temperature outside the box for 30 minutes out of the reach of children.
- Do not warm the pre-filled pen in any other way (for example, do not warm it in a microwave or in hot water).
- Do not remove the pre-filled pen’s cap while allowing it to reach room temperature.

Get the rest of your equipment ready

- While you are waiting you can get the rest of your equipment ready, including an alcohol swab, a cotton ball or gauze and a sharps container.

Check the liquid in the pre-filled pen

- Look through the viewing window to make sure that the liquid in the pre-filled pen is clear to slightly opalescent (having a pearl-like shine) and colourless to light yellow. The solution can be used if it contains a few small translucent or white particles of protein.
- You will also notice an air bubble, which is normal.
- Do not use the pre-filled pen if the liquid is the wrong colour, cloudy, or contains larger particles. If this happens, talk to your doctor or pharmacist.

2. Choosing and preparing the injection site (see figure 2)

- You can inject the medicine into the front of the middle thighs.
- You can use the stomach (abdomen) below the belly button, except for approximately the 5 cm area directly underneath the belly button.
- Do not inject into areas where the skin is tender, bruised, red, scaly, hard or has scars or stretch marks.

- If multiple injections are required for a single administration, the injections should be administered at different injection sites.

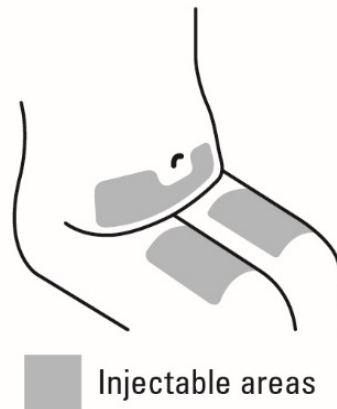

Figure 2

⚠ DO NOT inject into the arm to avoid failure of the pre-filled pen and/or unintentional injury.

Wash hands and clean injection site

- Wash your hands thoroughly with soap and warm water.
- Wipe the injection site with an alcohol swab.
- Allow the skin to dry before injecting. Do not fan or blow on the clean area.
- Do not touch this area again before giving the injection.

3. Injecting the medicine

- The cap should not be removed until you are ready to inject the medicine.
- The medicine should be injected within 5 minutes after the cap has been removed.

Remove the cap (figure 3)

- When you are ready to inject, twist the cap slightly to break the security seal.
- Pull the cap off and throw it away after your injection.
- Do not put the cap back on because it may damage the needle inside the pre-filled pen.
- Do not use the pre-filled pen if it is dropped without the cap in place. If this happens please contact your doctor or pharmacist.

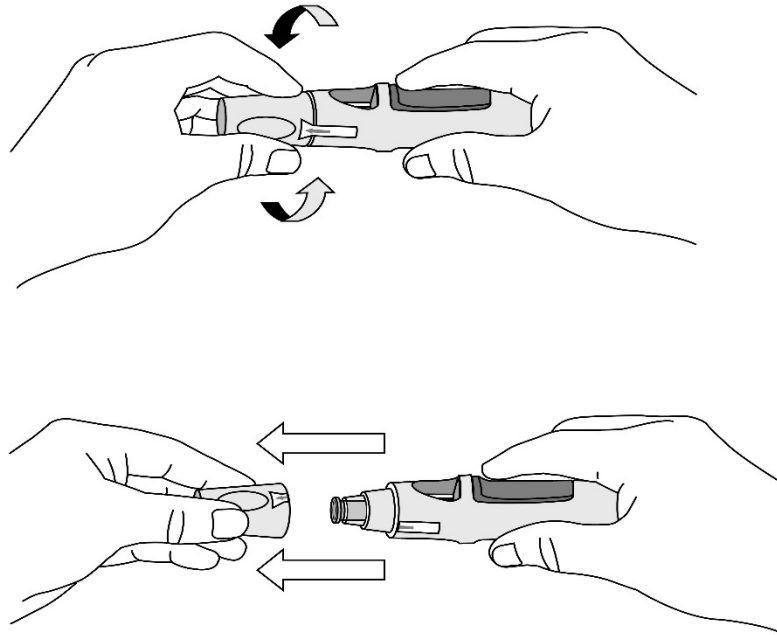

Figure 3

Push the pre-filled pen against the skin (see figures 4 and 5) without pinching the skin.



Figure 4

- Hold the pre-filled pen comfortably with one hand **above the blue button**.
- Make sure the green safety sleeve is stable and is as flat as possible against your skin. If the pre-filled pen is not stable during the injection, you risk bending the needle.
- DO NOT pinch the skin to avoid unintentional needlestick injury.
- **DO NOT** touch or press the blue button while positioning the pre-filled pen onto your skin.

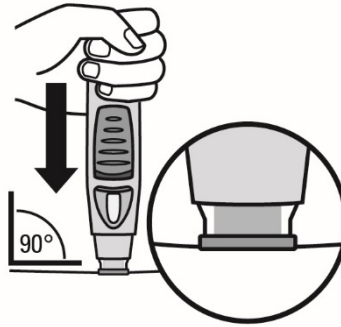

Figure 5

- Push the open end of the pre-filled pen against the skin at a 90-degree angle. Apply enough pressure to slide the green safety sleeve up and to maintain it inside the clear cover. Only the wider portion of the green safety sleeve remains outside of the clear cover.
- DO NOT press the blue button until after the safety sleeve slides into the clear cover. Pushing the blue button before the safety sleeve is depressed can lead to pen failure.
- Inject without pinching the skin.

Press button to inject (see figures 6 and 7)

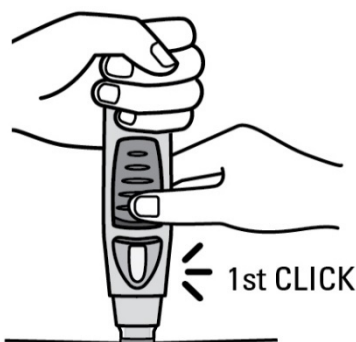

Figure 6

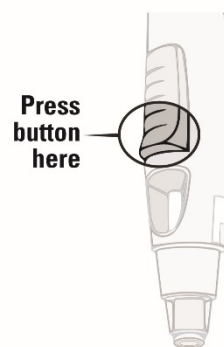

Figure 7

- Continue to push the pre-filled pen against your skin. **Use your other hand** to press the **raised part of the blue button** to start your injection. Do not press the button unless the pre-filled pen is **pressed against your skin** and the safety sleeve slides into the clear cover.
- Once the button is pressed, it will remain pressed in so you do not need to keep pressure on it.

- If the button seems hard to depress, don't press the button harder. Let go of the button, lift the pre-filled pen and start again. Ensure no pressure is on the button until the green safety sleeve is fully depressed against the skin, then press the raised part of the button.
- **You will hear a loud 'click' sound – don't be alarmed.** The first 'click' means that the needle has been inserted and the injection has started. You may or may not feel a needle prick at this time.

Do not lift the pre-filled pen away from your skin. If you pull the pre-filled pen away from your skin, you may not get your full dose of medicine.

Continue to hold until the second 'click' (see figure 8), it usually takes about 3 to 6 seconds, but may take up to 15 seconds for you to hear the second 'click' sound.

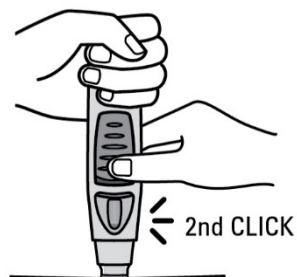

Figure 8

- **Continue to hold the pre-filled pen against your skin until you hear a second 'click' (indicating that the injection has finished and the needle has gone back into the pre-filled pen).**
- Lift the pre-filled pen from the injection site.
- Note: If you do not hear the second 'click', wait 15 seconds from the time you first press the button and then lift the autoinjector from the injection site.

4. After the injection

Use a cotton ball or gauze

- There may be a small amount of blood or liquid at the injection site. This is normal.
- You can press a cotton ball or gauze over the injection site for 10 seconds.

- You may cover the injection site with a small adhesive bandage, if necessary.
- Do not rub your skin.

Check the window – a yellow indicator confirms proper administration (see figure 9)

- The yellow indicator is connected to the plunger of the pre-filled pen. If the yellow indicator is not shown in the window, the plunger has not advanced adequately, and the injection has not occurred.
- The yellow indicator will fill about half of the viewing window. This is normal.
- Talk to your doctor or pharmacist if the yellow indicator is not visible in the window or if you suspect that you may not have received a complete dose. Do not administer a second dose without speaking to your doctor.

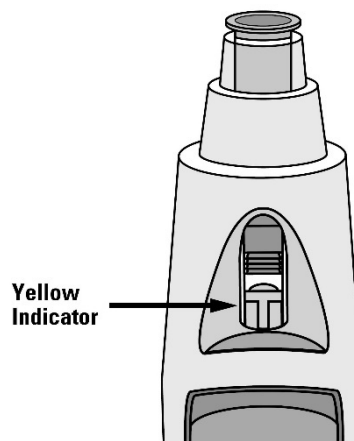

Figure 9

Throw the pre-filled pen away (see figure 10)

- Place your pen in a sharps container straight away. Make sure you dispose of the bin as instructed by your doctor or nurse when the container is full.

If you feel that something has gone wrong with the injection or if you are not sure, talk to your doctor or pharmacist.



Figure 10

Package Leaflet: Information for the user

SIMPONI® SOLUTION FOR INJECTION

Simponi 100 mg solution for injection in pre-filled syringe

golimumab

Read all of this leaflet carefully before you start using this medicine because it contains important information for you.

- Keep this leaflet. You may need to read it again.
- If you have any further questions, ask your doctor, pharmacist or nurse.
- This medicine has been prescribed for you only. Do not pass it on to others. It may harm them, even if their signs of illness are the same as yours.
- If you get any side effects, talk to your doctor, pharmacist or nurse. This includes any possible side effects not listed in this leaflet. See section 4.

Your doctor will also give you a Patient Reminder Card, which contains important safety information you need to be aware of before and during your treatment with Simponi.

What is in this leaflet

1. What Simponi is and what it is used for
2. What you need to know before you use Simponi
3. How to use Simponi
4. Possible side effects
5. How to store Simponi
6. Contents of the pack and other information

1. What Simponi is and what it is used for

Simponi contains the active substance called golimumab.

Simponi belongs to a group of medicines called 'TNF blockers'. It is used **in adults** for the treatment of the following inflammatory diseases:

- Rheumatoid arthritis
- Psoriatic arthritis
- Axial spondyloarthritis, including ankylosing spondylitis and non-radiographic axial spondyloarthritis
- Ulcerative colitis

Simponi works by blocking the action of a protein called 'tumour necrosis factor alpha' (TNF- α). This protein is involved in inflammatory processes of the body, and blocking it can reduce the inflammation in your body.

Rheumatoid arthritis

Rheumatoid arthritis is an inflammatory disease of the joints. If you have active rheumatoid arthritis

- you will first be given other medicines. If you do not respond well enough to these medicines, you may be given Simponi which you will take in combination with another medicine called methotrexate to:
- Reduce the signs and symptoms of your disease.
- Slow down the damage to your bones and joints.
- Improve your physical function.

Psoriatic arthritis

Psoriatic arthritis is an inflammatory disease of the joints, usually accompanied by psoriasis, an inflammatory disease of the skin. If you have active psoriatic arthritis you will first be given other medicines. If you do not respond well enough to these medicines, you may be given Simponi to:

- Reduce the signs and symptoms of your disease.
- Slow down the damage to your bones and joints.
- Improve your physical function.

Ankylosing spondylitis and non-radiographic axial spondyloarthritis

Ankylosing spondylitis and non-radiographic axial spondyloarthritis are inflammatory diseases of the spine. If you have ankylosing spondylitis or non-radiographic axial spondyloarthritis, you will first be given other medicines. If you do not respond well enough to these medicines, you may be given Simponi to:

- Reduce the signs and symptoms of your disease.
- Improve your physical function.

Ulcerative colitis

Ulcerative colitis is an inflammatory disease of the bowel. If you have ulcerative colitis you will first be given other medicines. If you do not respond well enough to these medicines, you will be given Simponi to treat your disease.

2. What you need to know before you use Simponi

Do not use Simponi:

- If you are allergic (hypersensitive) to golimumab or any of the other ingredients of this medicine (listed in Section 6).
- If you have tuberculosis (TB) or any other severe infection.
- If you have moderate or severe heart failure.

If you are not sure if any of the above applies to you, talk to your doctor, pharmacist or nurse before using Simponi.

Warnings and precautions

Talk to your doctor, pharmacist or nurse before using Simponi.

Infections

Tell your doctor straight away if you already have or get any symptoms of infection, during or after your treatment with Simponi. Symptoms of infection include fever, cough, shortness of breath, flu-like symptoms, diarrhoea, wounds, dental problems or a burning feeling when urinating.

- You may get infections more easily while using Simponi.
- Infections may progress more rapidly and may be more severe. In addition, some previous infections may reappear.

Tuberculosis (TB)

Tell your doctor straight away if symptoms of TB appear during or after your treatment. Symptoms of TB include persistent cough, weight loss, tiredness, fever or night sweats.

- Cases of TB have been reported in patients treated with Simponi, in rare occasions even in patients who have been treated with medicines for TB. Your doctor will test you to see if you have TB. Your doctor will record these tests on your Patient Reminder Card.
- It is very important that you tell your doctor if you have ever had TB, or if you have been in close contact with someone who has had or has TB.
- If your doctor feels that you are at risk of TB, you may be treated with medicines for TB before you begin using Simponi.

Hepatitis B virus (HBV)

- Tell your doctor if you are a carrier or if you have or have had HBV before you are given Simponi.
- Tell your doctor if you think you might be at risk of contracting HBV
- Your doctor should test you for HBV
- Treatment with TNF blockers such as Simponi may result in reactivation of HBV in patients who carry this virus, which can be life-threatening in some cases.

Invasive fungal infections

If you have lived in or travelled to an area where infections caused by specific type of fungi that can affect the lungs or other parts of the body (called histoplasmosis, coccidioidomycosis, or blastomycosis), are common, tell your doctor straight away. Ask your doctor if you don't know if these fungal infections are common in the area in which you have lived or travelled.

Cancer and lymphoma

Tell your doctor if you have ever been diagnosed with lymphoma (a type of blood cancer) or any other cancer before you use Simponi.

- If you use Simponi or other TNF blockers, your risk for developing lymphoma or another cancer may increase.
- Patients with severe rheumatoid arthritis and other inflammatory diseases, who have had the disease for a long time, may be at higher than average risk of developing lymphoma.
- There have been cases of cancers, including unusual types, in children and teenage patients taking TNF-blocking agents, which sometimes resulted in death.
- On rare occasions, a specific and severe type of lymphoma called hepatosplenic T-cell lymphoma has been observed in patients taking other TNF-blockers. Most of these patients were adolescent or young adult males. This type of cancer has usually resulted in death. Almost all of these patients had also received medicines known as azathioprine or 6-mercaptopurine. Tell your doctor if you are taking azathioprine or 6-mercaptopurine with Simponi.
- Patients with severe persistent asthma, chronic obstructive pulmonary disease (COPD), or are heavy smokers may be at increased risk for cancer with Simponi treatment. If you have severe persistent asthma, COPD or are a heavy smoker, you should discuss with your doctor whether treatment with a TNF blocker is appropriate for you.
- Some patients treated with golimumab have developed certain kinds of skin cancer. If any changes in the appearance of the skin or growths on the skin occur during or after therapy, tell your doctor.

Heart failure

Tell your doctor straight away if you get new or worsening symptoms of heart failure. Symptoms of heart failure include shortness of breath or swelling of your feet.

- New and worsening congestive heart failure has been reported with TNF blockers, including Simponi. Some of these patients died.
- If you have mild heart failure and you are being treated with Simponi, you must be closely monitored by your doctor.

Nervous system disease

Tell your doctor straight away if you have ever been diagnosed with or develop symptoms of a demyelinating disease such as multiple sclerosis. Symptoms may include changes in your vision, weakness in your arms or legs or numbness or tingling in any part of your body. Your doctor will decide if you should receive Simponi.

Operations or dental procedures

- Talk to your doctor if you are going to have any operations or dental procedures.
- Tell your surgeon or dentist performing the procedure that you are having treatment with Simponi by showing them your Patient Reminder Card.

Autoimmune disease

Tell your doctor if you develop symptoms of a disease called lupus. Symptoms include persistent rash, fever, joint pain and tiredness.

- On rare occasions, people treated with TNF blockers have developed lupus.

Blood disease

In some patients the body may fail to produce enough of the blood cells that help your body fight infections or help you to stop bleeding. If you develop a fever that does not go away, bruise or bleed very easily or look very pale, call your doctor right away. Your doctor may decide to stop treatment.

If you are not sure if any of the above applies to you, talk to your doctor or pharmacist before using Simponi.

Vaccinations

Talk to your doctor if you have had, or are due to have a vaccine.

- You should not receive certain (live) vaccines while using Simponi.
- Certain vaccinations may cause infections. If you received Simponi while you were pregnant, your baby may be at higher risk for getting such an infection for up to approximately six months after the last dose you received during pregnancy. It is important that you tell your baby's doctors and other health care professionals about your Simponi use so they can decide when your baby should receive any vaccine.

Therapeutic infectious agents

Talk to your doctor if you have recently received or are scheduled to receive treatment with a therapeutic infectious agent (such as BCG instillation used for the treatment of cancer).

Allergic reactions

Tell your doctor straight away if you develop symptoms of an allergic reaction after your treatment with Simponi. Symptoms of an allergic reaction may include swelling of the face, lips, mouth or throat which may cause difficulty in swallowing or breathing, skin rash, hives, swelling of the hands, feet or ankles.

- Some of these reactions may be serious or, rarely, life-threatening.
- Some of these reactions occurred after the first administration of Simponi.

Children and adolescents

Simponi 100 mg is not recommended for children and adolescents (younger than 18 years).

Other medicines and Simponi

- Tell your doctor or pharmacist if you are using, have recently used or might use any other medicines, including any other medicines to treat rheumatoid arthritis, psoriatic arthritis, ankylosing spondylitis, non-radiographic axial spondyloarthritis, or ulcerative colitis.
- You should not take Simponi with medicines containing the active substance anakinra or abatacept. These medicines are used for the treatment of rheumatic diseases.
- Tell your doctor or pharmacist if you are taking any other medicines that affect your immune system.
- You should not receive certain (live) vaccines while using Simponi.

If you are not sure if any of the above applies to you, talk to your doctor or pharmacist before using Simponi.

Pregnancy and breast-feeding

Talk to your doctor before using Simponi if:

- You are pregnant or are planning to become pregnant while using Simponi. There is limited information about the effects of this medicine in pregnant women. If you are being treated with Simponi, you must avoid becoming pregnant by using adequate contraception during your treatment and for at least 6 months after the last Simponi injection. Simponi should only be used during pregnancy if it is clearly necessary for you.
- Before starting breast-feeding, your last treatment with Simponi must be at least 6 months ago. You must stop breast-feeding if you are to be given Simponi.
- If you received Simponi during your pregnancy, your baby may have a higher risk for getting an infection. It is important that you tell your baby's doctors and other health care professionals about your Simponi use before the baby receives any vaccine (for more information see section on vaccination).

If you are pregnant or breast-feeding, think you may be pregnant or are planning to have a baby, ask your doctor or pharmacist for advice before taking this medicine.

Driving and using machines

Simponi has minor influence on your ability to drive and use tools or machines. Dizziness may however occur after you take Simponi. If this happens, do not drive or use any tools or machines.

Simponi contains latex and sorbitol

Latex sensitivity

A part of the pre-filled syringe, the needle cover, contains latex. Because latex may cause severe allergic reactions, talk to your doctor before using Simponi if you or your carer are allergic to latex.

Sorbitol intolerance

This medicine contains 41 mg sorbitol (E420) in each pre-filled syringe.

3. How to use Simponi

Always use this medicine exactly as your doctor or pharmacist has told you. You should check with your doctor or pharmacist if you are not sure.

How much Simponi is given

Rheumatoid arthritis, psoriatic arthritis, and axial spondyloarthritis, including ankylosing spondylitis and non-radiographic axial spondyloarthritis:

- The recommended dose is 50 mg given once a month, on the same date each month.
- Talk to your doctor before taking your fourth dose. Your doctor will determine if you should continue Simponi treatment.
 - If you weigh more than 100 kg, the dose might be increased to 100 mg (the content of 1 pre-filled syringe) given once a month, on the same date each month.

Ulcerative colitis

- The table below shows how you will usually use this medicine.

Initial treatment	A starting dose of 200 mg (the contents of 2 pre-filled syringes) followed by 100 mg (the contents of 1 pre-filled syringe) 2 weeks later.
Maintenance treatment	<ul style="list-style-type: none">• In patients weighing less than 80 kg, 50 mg (the 50 mg pre-filled pen or pre-filled syringe must be used to administer this dose) 4 weeks after your last treatment, then every 4 weeks thereafter. Your doctor may decide to prescribe 100 mg (the contents of 1 pre-filled syringe) depending on how well Simponi works for you.• In patients weighing 80 kg or more, 100 mg (the contents of 1 pre-filled syringe) 4 weeks after your last treatment, then every 4 weeks thereafter.

How Simponi is given

- Simponi is given by injection under the skin (subcutaneously).

- At the start, your doctor or nurse may inject Simponi. However, you and your doctor may decide that you may inject Simponi yourself. In this case you will get training on how to inject Simponi yourself.

Talk to your doctor if you have any questions about giving yourself an injection. You will find detailed "Instructions for Use" at the end of this leaflet.

If you use more Simponi than you should

If you have used or been given too much Simponi (either by injecting too much on a single occasion, or by using it too often), talk to your doctor or pharmacist straight away. Always take the outer carton and this leaflet with you, even if it is empty.

If you forget to use Simponi

If you forget to use Simponi on your planned date, inject the forgotten dose as soon as you remember.

Do not use a double dose to make up for a forgotten dose.

When to inject your next dose:

- If you are less than 2 weeks late, inject the forgotten dose as soon as you remember and stay on your original schedule.
- If you are more than 2 weeks late, inject the forgotten dose as soon as you remember and talk to your doctor or pharmacist to ask when you need to take the next dose.

If you are not sure what to do, talk to your doctor or pharmacist.

If you stop using Simponi

If you are considering stopping Simponi, talk to your doctor or pharmacist first.

If you have any further questions on the use of this medicine, ask your doctor, pharmacist or nurse.

4. Possible side effects

Like all medicines, this medicine can cause side effects, although not everybody gets them. Some patients may experience serious side effects and may require treatment. The risk of certain side effects is greater with the 100 mg dose compared with the 50 mg dose. Side effects may appear up to several months after the last injection.

Tell your doctor straight away if you notice any of the following serious side effects of Simponi which include:

- **allergic reactions which may be serious, or rarely, life-threatening (rare).** Symptoms of an allergic reaction may include swelling of the face, lips, mouth or throat which may cause difficulty in swallowing or breathing, skin rash, hives, swelling of the hands, feet or ankles. Some of these reactions occurred after the first administration of Simponi.
 - **serious infections (including TB, bacterial infections including serious blood infections and pneumonia, severe fungal infections and other opportunistic infections) (common).** Symptoms of an infection can include fever, tiredness, (persistent) cough, shortness of breath, flu-like symptoms, weight loss, night sweats, diarrhoea, wounds, dental problems and a burning feeling when urinating.
 - **reactivation of hepatitis B virus if you are a carrier or have had hepatitis B before (rare).** Symptoms can include yellowing of the skin and eyes, dark brown-coloured urine, right-sided abdominal pain, fever, feeling sick, being sick, and feeling very tired.
 - **nervous system disease such as multiple sclerosis (rare).** Symptoms of nervous system disease can include changes in your vision, weakness in your arms or legs, numbness or tingling in any part of your body.
 - **cancer of the lymph nodes (lymphoma) (rare).** Symptoms of lymphoma can include swelling of the lymph nodes, weight loss, or fever.
 - **heart failure (rare).** Symptoms of heart failure can include shortness of breath or swelling of your feet.
 - **signs of immune system disorders called:**
 - **lupus (rare).** Symptoms can include joint pain or a rash on cheeks or arms that is sensitive to the sun.
 - **sarcoidosis (rare).** Symptoms can include a persistent cough, being short of breath, chest pain, fever, swelling of your lymph nodes, weight loss, skin rashes, and blurred vision.
 - **swelling of small blood vessels (vasculitis) (rare).** Symptoms can include fever, headache, weight loss, night sweats, rash, and nerve problems such as numbness and tingling.
 - **skin cancer (uncommon).** Symptoms of skin cancer can include changes in the appearance of your skin or growths on your skin.
 - **blood disease (common).** Symptoms of blood disease can include a fever that does not go away, bruising or bleeding very easily or looking very pale.
 - **blood cancer (leukaemia) (rare).** Symptoms of leukaemia can include fever, feeling tired, frequent infections, easy bruising, and night sweats.
- Tell your doctor straight away if you notice any of the above symptoms.

The following additional side effects have been observed with Simponi:

Very common side effects (may affect more than 1 in 10 people):

- Upper respiratory tract infections, sore throat or hoarseness, runny nose

Common side effects (may affect up to 1 in 10 people):

- Abnormal liver tests (increased liver enzymes) found during blood tests done by your doctor

- Feeling dizzy
- Headache
- Feeling numb or having a tingling feeling
- Superficial fungal infections
- Abscess
- Bacterial infections (such as cellulitis)
- Low red blood cell counts
- Low white blood cell counts
- Positive blood lupus test
- Allergic reactions
- Indigestion
- Stomach pain
- Feeling sick (nausea)
- Flu
- Bronchitis
- Sinus infection
- Cold sores
- High blood pressure
- Fever
- Asthma, shortness of breath, wheezing
- Stomach and bowel disorders which include inflammation of the stomach lining and colon which may cause fever
- Pain and ulcers in the mouth
- Injection site reactions (including redness, hardness, pain, bruising, itching, tingling and irritation)
- Hair loss
- Rash and itching of the skin
- Difficulty sleeping
- Depression
- Feeling weak
- Bone fractures
- Chest discomfort

Uncommon side effects (may affect up to 1 in 100 people):

- Kidney infection
- Cancers, including skin cancer and non-cancerous growths or lumps, including skin moles

- Skin blisters
- Severe infection throughout the body (sepsis), sometimes including low blood pressure (septic shock)
- Psoriasis (including on the palms of your hand and/or the soles of your feet and/or in the form of skin blisters)
- Low platelet count
- Combined low platelet, red, and white blood cell count
- Thyroid disorders
- Increase in blood sugar levels
- Increase in blood cholesterol levels
- Balance disorders
- Vision disturbances
- Inflamed eye (conjunctivitis)
- Eye allergy
- Sensation of heart beating irregularly
- Narrowing of the blood vessels in the heart
- Blood clots
- Flushing
- Constipation
- Chronic inflammatory condition of the lungs
- Acid reflux
- Gall stones
- Liver disorders
- Breast disorders
- Menstrual disorders

Rare side effects (may affect up to 1 in 1,000 people):

- Failure of the bone marrow to produce blood cells
- Severely decreased number of white blood cells
- Infection of the joints or the tissue around them
- Impaired healing
- Inflammation of blood vessels in internal organs
- Leukaemia
- Melanoma (a type of skin cancer)
- Merkel cell carcinoma (a type of skin cancer)
- Lichenoid reactions (itchy reddish-purple skin rash and/or threadlike white-grey lines on mucous membranes)

- Scaly, peeling skin
- Immune disorders that could affect the lungs, skin and lymph nodes (most commonly presenting as sarcoidosis)
- Pain and discolouration in the fingers or toes
- Taste disturbances
- Bladder disorders
- Kidney disorders
- Inflammation of the blood vessels in your skin which results in rash

Side effects of which the frequency is not known:

- A rare blood cancer affecting mostly young people (hepatosplenic T-cell lymphoma)
- Kaposi's sarcoma, a rare cancer related to infection with human herpes virus 8. Kaposi's sarcoma most commonly appears as purple lesions on the skin
- Worsening of a condition called dermatomyositis (seen as a skin rash accompanying muscle weakness)

Reporting of side effects

If you get any side effects, talk to your doctor, pharmacist or nurse. This includes any possible side effects not listed in this leaflet. You can also report side effects directly via the national reporting system. By reporting side effects you can help provide more information on the safety of this medicine.

5. How to store Simponi

- Keep this medicine out of the sight and reach of children.
- Do not use this medicine after the expiry date which is stated on the label and the carton after "EXP". The expiry date refers to the last day of that month.
- Store in a refrigerator (2°C-8°C). Do not freeze.
- Keep the pre-filled syringe in the outer carton in order to protect it from light.
- This medicine can also be stored out of the refrigerator at temperatures up to a maximum of 25°C for a single period of up to 30 days, but not beyond the original expiry date printed on the carton. Write the new expiry date on the carton including day/month/year (no more than 30 days after the medicine is removed from the refrigerator). Do not return this medicine to refrigerator if it has reached room temperature. Discard this medicine if not used by the new expiry date or the expiry date printed on the carton, whichever is earlier.
- Do not use this medicine if you notice that the liquid is not a clear to light yellow colour, cloudy, or contains foreign particles.
- Do not throw away any medicines via wastewater or household waste. Ask your doctor or pharmacist how to throw away medicines you no longer use. These measures will help to protect the environment.

6. Contents of the pack and other information

What Simponi contains

The active substance is golimumab. One 1 mL pre-filled syringe contains 100 mg of golimumab.

The other ingredients are sorbitol (E420), histidine, histidine hydrochloride monohydrate, polysorbate 80 and water for injections. For more information on sorbitol (E420), see Section 2.

What Simponi looks like and contents of the pack

Simponi is supplied as solution for injection in a single-use pre-filled syringe. Simponi is available in packs containing 1 pre-filled syringe and multipacks containing 3 (3 packs of 1) pre-filled syringes. Not all pack sizes may be marketed.

The solution is clear to slightly opalescent (having a pearl-like shine), colourless to light yellow and may contain a few small translucent or white particles of protein. Do not use Simponi if the solution is discoloured, cloudy or you can see foreign particles in it.

For any information about this medicine, please contact the local representative of the Marketing Authorisation Holder.

This leaflet was last revised in

08-Mar-2024 (EUPIIL version 22-Jun-2023)

MARKETING AUTHORISATION NUMBER(S) AND DATE OF AUTHORIZATION

Product Name	License number	Manufactured by	Date of Authorization
SIMPONI SOLUTION FOR INJECTION	1C 1/57 (NB)	Baxter Pharmaceutical Solution LLC, Indiana, USA	24-Jan-2014

Imported by

Janssen-Cilag Ltd., Bangkok, Thailand

To report Suspected Adverse Reactions, please contact us at aepqciacth@its.jnj.com

For any product information, please contact us at medinfosea@its.jnj.com

Please see full prescribing information at <https://ndi.fda.moph.go.th>

INSTRUCTIONS FOR USE

Approval on 8-Mar-2024

If you would like to self inject Simponi, you must be trained by a healthcare professional to prepare an injection and give it to yourself. If you have not been trained, please contact your doctor, nurse or pharmacist to schedule a training session.

In these instructions:

1. Preparing for use of the pre-filled syringe
2. Choosing and preparing the injection site
3. Injecting the medicine
4. After the injection

The diagram below (see figure 1) shows what the pre-filled syringe looks like.

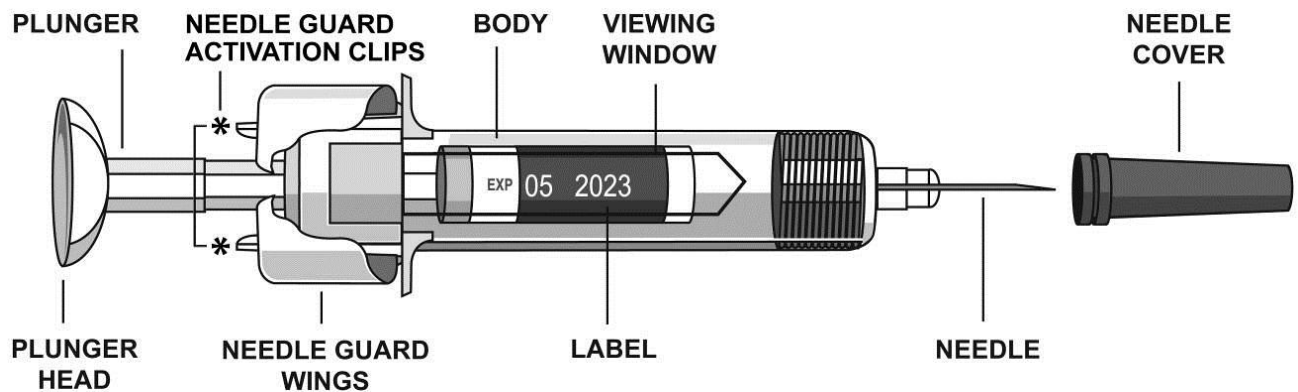

Figure 1

1. Preparing for use of the pre-filled syringe

Hold the pre-filled syringe by the body of the pre-filled syringe

- Do not hold by the plunger head, plunger, needle guard wings, or needle cover.
- Do not pull back on the plunger at any time.
- Do not shake the pre-filled syringe at any time.
- Do not remove the needle cover from the pre-filled syringe until instructed to do so.
- Do not touch the needle guard activation clips (as indicated by asterisks * in figure 1) to prevent prematurely covering the needle with the needle guard.

Check the number of pre-filled syringes

Check the pre-filled syringes to make sure

- the number of pre-filled syringes and strength is correct
 - If your dose is 100 mg, you will get one 100 mg pre-filled syringe

- If your dose is 200 mg, you will get two 100 mg pre-filled syringes and you will need to give yourself two injections. Choose different sites for these injections and give the injections one right after the other.

Check expiry date (see figure 2)

- Check the expiration date printed or written on the carton.
- Check the expiration date (as indicated by "EXP") on the label by looking through the viewing window located within the body of the pre-filled syringe.
- If you cannot see the expiration date through the viewing window, hold the pre-filled syringe by its body and rotate the needle cover to line up the expiration date to the viewing window.

Do not use the pre-filled syringe if the expiration date has passed. The printed expiration date refers to the last day of the month. Please contact your doctor or pharmacist for assistance.

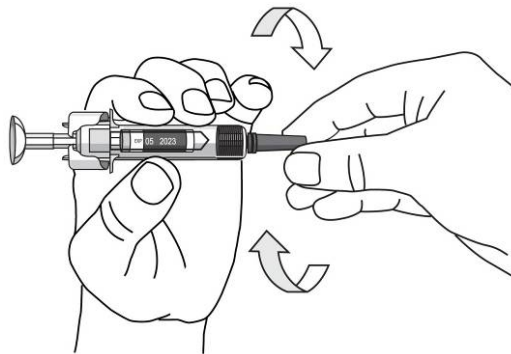

Figure 2

Wait 30 minutes to allow pre-filled syringe to reach room temperature

- To ensure proper injection, allow the pre-filled syringe to sit at room temperature outside the box for 30 minutes, out of the reach of children.

Do not warm the pre-filled syringe in any other way (for example, do not warm it in a microwave or in hot water).

Do not remove the pre-filled syringe's needle cover while allowing it to reach room temperature.

Get the rest of your equipment ready

While you are waiting you can get the rest of your equipment ready, including an alcohol swab, a cotton ball or gauze and a sharps container.

Check the liquid in the pre-filled syringe

- Hold the pre-filled syringe by its body with the covered needle pointing downward.

- Look at the liquid through the viewing window of the pre-filled syringe and make sure that it is clear to slightly opalescent (having a pearl-like shine) and colourless to light yellow. The solution can be used if it contains a few small translucent or white particles of protein.
- If you cannot see the liquid through the viewing window, hold the pre-filled syringe by its body and rotate the needle cover to line up the liquid to the viewing window (see figure 2).

Do not use the pre-filled syringe if the liquid is the wrong colour, cloudy, or contains larger particles. If this happens, talk to your doctor or pharmacist.

2. Choosing and preparing the injection site (see figure 3)

- You usually inject the medicine into the front of the middle thighs.
- You can also use the lower stomach (abdomen) below the belly button, except for approximately the 5 cm area directly underneath the belly button.
- Do not inject into areas where the skin is tender, bruised, red, scaly, hard or has scars or stretch marks.
- If multiple injections are required for a single administration, the injections should be administered at different sites on the body.

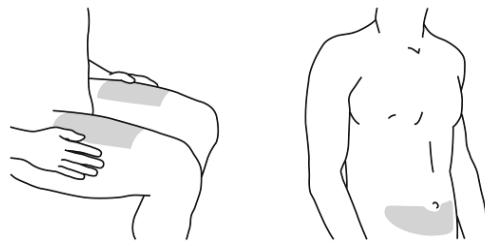

Figure 3

Injection site selection for caregivers (see figure 4)

- If a caregiver is giving you the injection, they can also use the outer area of the upper arms.
- Again, all sites mentioned can be used regardless of your body type or size.

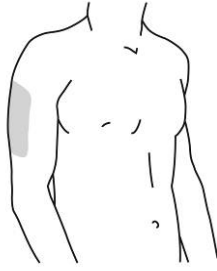

Figure 4

Preparing injection site

- Wash your hands thoroughly with soap and warm water.
- Wipe the injection site with an alcohol swab.
- Allow the skin to dry before injecting. Do not fan or blow on the clean area.

Do not touch this area again before giving the injection.

3. Injecting the medicine

The needle cover should not be removed until you are ready to inject the medicine. The medicine should be injected within 5 minutes after the needle cover has been removed.

Do not touch the plunger during needle cover removal.

Remove the needle cover (see figure 5)

- When you are ready to inject, hold the body of the pre-filled syringe with one hand.
- Pull the needle cover straight off and throw it away after your injection. Do not touch the plunger while you do this.
- You may notice an air bubble in the pre-filled syringe or a drop of liquid at the end of the needle. These are both normal and do not need to be removed.
- Inject the dose promptly after removing the needle cover.

Do not touch the needle or allow it to touch any surface.

Do not use the pre-filled syringe if it is dropped without the needle cover in place. If this happens, please contact your doctor or pharmacist.

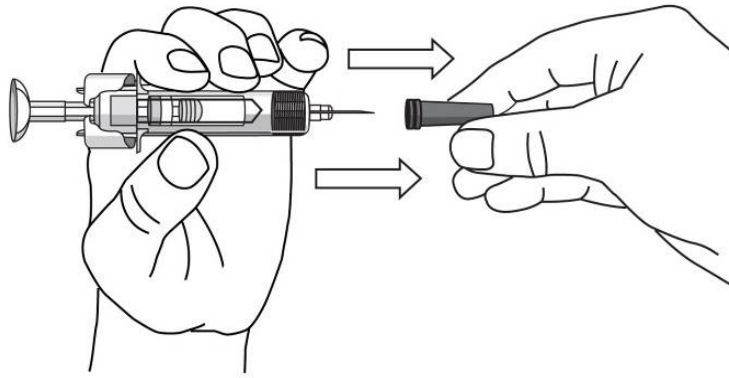

Figure 5

Position the pre-filled syringe to inject

- Hold the body of the pre-filled syringe with one hand between the middle and index fingers and place the thumb on top of the plunger head and use the other hand to gently pinch the area of skin that you previously cleaned. Hold firmly.

Do not pull back on the plunger at any time.

Inject the medicine

- Place the needle at approximately a 45-degree angle to the pinched skin. In a single and swift motion, insert the needle through the skin as far as it will go (see figure 6).

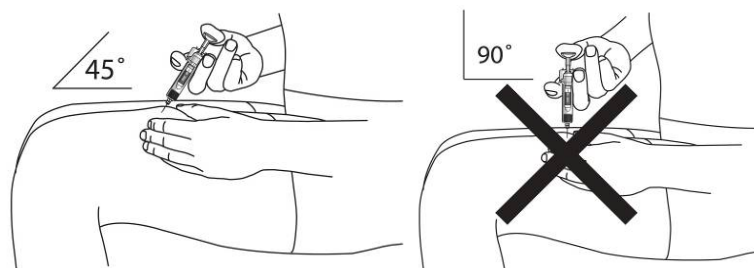

Figure 6

- Inject all of the medicine by pushing in the plunger until the plunger head is completely between the needle guard wings (see figure 7).



Figure 7

- When the plunger is pushed as far as it will go, continue to keep the pressure on the plunger head, take out the needle and let go of the skin (see figure 8).

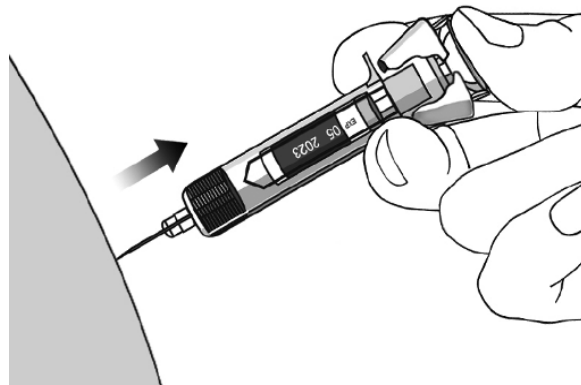

Figure 8

- Slowly take your thumb off the plunger head to allow the empty pre-filled syringe to move up until the entire needle is covered by the needle guard, as shown by the figure 9:

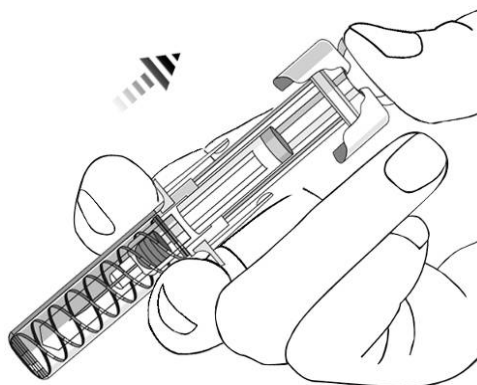

Figure 9

4. After the injection

Use a cotton ball or gauze

- There may be a small amount of blood or liquid at the injection site. This is normal.
- You can press a cotton ball or gauze over the injection site and hold for 10 seconds.
- You may cover the injection site with a small adhesive bandage, if necessary.

Do not rub your skin.

Throw the pre-filled syringe away (see figure 10)

- Place your pre-filled syringe in a sharps container straight away. Make sure you dispose of the bin as instructed by your doctor or nurse.

Do not attempt to recap the needle.

Do not ever re-use a pre-filled syringe, for your safety and health and for the safety of others.

If you feel that something has gone wrong with the injection or if you are not sure, talk to your doctor or pharmacist.



Figure 10